

Owner/ Developer
Amsterdam Avenue
Redevelopment Associates, LLC
c/o SJP Residential Properties
Eleven Times Square
New York, NY 10036

Architect
Elkus Manfredi Architects
60 Broadway
Boston, MA 02210

Interior Architect
Cetra Ruddy
584 Broadway, Suite 401
New York, NY USA 10012

Structural Engineer
DeSimone Consulting Engineers
140 Broadway, 25th Floor
New York, NY 10011

MEP/ FP Engineer
AKF Group
One Liberty Plaza
165 Broadway, 22 Floor
New York, New York 10006

Geotechnical Engineer
Mueser Rutledge
225 West 34th Street, 10th Floor
New York, NY 10122

Civil Engineer
Stonefield Engineering & Design LLC
75 Orient Way, Suite 303
Rutherford, NJ 07070

Building Envelope Consultant
Vidaris, Inc.
360 Park Avenue South, 15 Floor
New York, NY 10010

Facade Maintenance Consultant
Etek Engineering, LLC
Hackensack, NJ 07601
160 Ames Street

Vertical Transportation Consultant
Joseph Neto & Associates
1430 Broadway, Suite 908
New York, New York 10006

Acoustics Consultant
Longman Lindsey
1410 Broadway, Suite 508
New York, NY 10018

200 AMSTERDAM AVENUE SUPPORT OF EXCAVATION AND UNDERPINNING

NOTES FOR SUPPORT OF EXCAVATION:

GENERAL

- DELINEATION OF DESIGN AND SPECIAL INSPECTION RESPONSIBILITY:
 - IF THE CONTRACTOR PROPOSES AN ALTERNATIVE DESIGN OR MODIFICATIONS TO THE DESIGN SHOWN, THEN:
 - ALTERNATIVES SUBMITTED BY THE CONTRACTOR MUST DEMONSTRATE EQUIVALENCE IN TERMS OF LIMITING GROUND MOVEMENT TO THE SYSTEM SHOWN BELOW HEREON.
 - THE CONTRACTOR SHALL RETAIN THE SERVICES OF A LICENSED PROFESSIONAL ENGINEER REGISTERED IN THE STATE OF NEW YORK OR THE DESIGN ENGINEER TO PREPARE ALL SUPPORT OF EXCAVATION AND UNDERPINNING DESIGN, AND DRAWINGS.
 - UNLESS THE ALT. DESIGN OR MODIFICATIONS ARE PREPARED BY THE DESIGN ENGINEER, MINIMUM 4 WEEKS PRIOR TO START OF THE WORK, THE CONTRACTOR SHALL SUBMIT SIGNED AND SEALED SUPPORT OF EXCAVATION AND UNDERPINNING CALCULATIONS AND DRAWINGS TO THE CONSTRUCTION MANAGER FOR REVIEW AND APPROVAL.
 - THE CONTRACTOR SHALL OBTAIN APPROVAL FROM THE NYC DOB FOR HIS ALTERNATIVE DESIGN.
 - THE OWNER WILL PROVIDE SPECIAL INSPECTION FOR ALL SUPPORT OF EXCAVATION AND UNDERPINNING WORK.
- ELEVATIONS ARE REFERENCED TO THE NORTH AMERICAN VERTICAL DATUM OF 1988 (NAVD88).
- BASE PLAN AND SECTIONS ARE COMPILED USING:
 - SURVEY DRAWING FOR BLOCK 146, LOTS 48, 50, 51, AND 52, DATED 3-26-2014, PREPARED BY LEONARD J. STRANDBERG AND ASSOCIATES, CONSULTING ENGINEERS AND LAND SURVEYORS, P.C.
 - FOUNDATION AND CELLAR FLOOR PLAN RECEIVED ON 10-28-2016, PREPARED BY DESIMONE CONSULTING ENGINEERS.
- PROPOSED FOUNDATIONS ARE SHOWN ON THESE DRAWINGS FOR REFERENCE ONLY. REFER TO STRUCTURAL DRAWINGS FOR ALL NEW FOUNDATION INFORMATION. CONTRACTOR SHALL CONFIRM SUBGRADES AND SLAB ELEVATIONS SHOWN ON THIS DRAWING WITH THOSE SHOWN ON THE STRUCTURAL DRAWINGS.
- THE SOE-SERIES DRAWINGS DO NOT ADDRESS SAFETY ISSUES RELATED TO THE EXCAVATION AND SHORING WORK. THE CONTRACTOR SHALL BE RESPONSIBLE FOR SITE SAFETY AND PROVIDE A SAFETY PLAN CONFORMING TO OSHA STANDARDS.
- CONTRACTOR SHALL PROVIDE BARRIERS AND FENCING AROUND THE EXCAVATION PER NYC DOB AND DOT REQUIREMENTS.
- CONTRACTOR SHALL VERIFY AND COORDINATE ALL DIMENSIONS AND CHECK FOR CLEARANCES, INCLUDING CLEARANCES WITH EXISTING SEWERS AND OTHER UTILITIES TO REMAIN, PRIOR TO THE START OF WORK. ACTUAL FIELD CONDITIONS MAY REQUIRE MODIFICATIONS TO THE CONSTRUCTION DETAILS SHOWN. CONFLICTS BETWEEN ACTUAL CONDITIONS AND DETAILS SHOWN SHALL BE BROUGHT TO THE CONSTRUCTION MANAGER'S ATTENTION FOR RESOLUTION.
- EXCAVATION SHORING ALONG AMSTERDAM AVENUE, THE DRIVEWAY, AND PARKING LOT ARE DESIGNED FOR A ROADWAY VERTICAL SURCHARGE OF 600 PSF PER THE NYCT FIELD DESIGN STANDARD, DG-453.
- THE NYC DOB SHALL BE NOTIFIED 24-48 HOURS PRIOR TO COMMENCEMENT OF EARTHWORK PER BC 3304.3.1.
- ALL SOE WORK SHALL BE PERFORMED IN ACCORDANCE WITH ADJACENT PROPERTY ACCESS AGREEMENTS.

MATERIALS AND TESTING

- STEEL SHAPES, PLATES AND OTHER MISCELLANEOUS STEEL SHALL CONFORM TO THE REQUIREMENTS OF ASTM A992 OR ASTM A572 WITH A MINIMUM YIELD STRENGTH OF 50 KSI.
- STEEL SOLDIER PIPE PILES SHALL CONFORM TO THE REQUIREMENTS OF API N80 WITH A MINIMUM YIELD STRENGTH OF 80 KSI. PIPE PILES SHALL BE FILLED WITH GROUT WHICH SHALL HAVE A MINIMUM COMPRESSIVE STRENGTH OF 4000 PSI AT 28 DAYS. MAKE A SET OF SIX GROUT CUBES FOR EACH DAY GROUTING IS PERFORMED. CUBES SHALL BE TESTED FOR 7, 14, AND 28 DAY COMPRESSIVE STRENGTHS.
- CONCRETE FOR HEELBLOCKS SHALL HAVE A MINIMUM COMPRESSIVE STRENGTH OF 4000 PSI AT 28 DAYS. THE CONTRACTOR SHALL SUBMIT A MIX DESIGN MEETING THE SPECIFICATION REQUIREMENTS FOR APPROVAL PRIOR TO PERFORMING THE WORK. MAKE A SET OF SIX CONCRETE CUBES FOR EACH DAY CONCRETE IS POURED. CUBES SHALL BE TESTED FOR 7, 14, AND 28 DAY COMPRESSIVE STRENGTHS.
- ALL WELDING SHALL BE DONE BY CERTIFIED WELDERS, USING E-70 LOW HYDROGEN ELECTRODES, AND SHALL CONFORM TO THE REQUIREMENTS OF AWS D1.1. ALL WELDS SHALL BE VISUALLY INSPECTED BY THE ENGINEER RESPONSIBLE FOR SPECIAL INSPECTIONS. SUBMIT WELDER CERTIFICATION TO THE CONSTRUCTION MANAGER.
- TIEBACK THREADBARS SHALL CONFORM TO THE REQUIREMENTS OF ASTM A722, GRADE 150 KSI. THREADBAR SIZE AND TIEBACK DESIGN LOADS ARE SHOWN ON THE SECTIONS. TIEBACK BOND LENGTHS SHOWN ON THESE DRAWINGS ARE MINIMUM LENGTHS. PRIOR TO THE START OF THE WORK, THE CONTRACTOR SHALL DETERMINE THE ADDITIONAL BOND LENGTH REQUIRED, IF ANY, TO OBTAIN THE TIEBACK DESIGN LOADS INDICATED ON THESE DRAWINGS BASED ON HIS OWN MEANS AND METHOD OF INSTALLATION. ALL TIEBACKS SHALL BE PERFORMANCE OR PROOF TESTED IN ACCORDANCE WITH PTI RECOMMENDATIONS AND LOCKED OFF AT 100% OF THE DESIGN LOAD.
- SLAB PINS AND HEEL BLOCK PINS SHALL CONFORM TO THE REQUIREMENTS OF ASTM A722, GRADE 150 KSI.
- GROUT FOR TIEBACKS SHALL HAVE A MINIMUM COMPRESSIVE STRENGTH OF 3000 PSI AT THE TIME OF PROOF TESTING. MAKE A SET OF SIX GROUT CUBES FOR EACH DAY GROUTING IS PERFORMED. CUBES SHALL BE TESTED FOR 7, 14, AND 28 DAY COMPRESSIVE STRENGTHS.
- TIMBER LAGGING SHALL BE ROUGH CUT FULL SIZE, CONSTRUCTION GRADE, WITH A MINIMUM ALLOWABLE BENDING STRESS OF 1200 PSI AND A MINIMUM ALLOWABLE SHEAR STRESS OF 175 PSI. LAGGING THICKNESS SHALL BE 3" FOR EXCAVATIONS LESS THAN 15 FEET AND 4" THICK FOR EXCAVATION GREATER THAN 15 FEET.

- ROCK BOLTS SHALL CONSIST OF THREADBARS CONFORMING TO THE REQUIREMENTS OF ASTM A722, GRADE 150 KSI. THREADBAR SIZE IS SHOWN ON THE SECTIONS. GROUT FOR ROCK BOLTS SHALL HAVE A MINIMUM COMPRESSIVE STRENGTH OF 5000 PSI AT 28 DAYS. MAKE A SET OF SIX GROUT CUBES FOR EACH DAY GROUTING IS PERFORMED. CUBES SHALL BE TESTED FOR 7, 14, AND 28 DAY COMPRESSIVE STRENGTHS OR UNTIL MINIMUM COMPRESSIVE STRENGTH IS REACHED.
- SHOTCRETE SHALL BE MINIMUM CORE GRADE 2 AND HAVE A MINIMUM COMPRESSIVE STRENGTH OF 4000 PSI AT 28 DAYS. THE CONTRACTOR SHALL SUBMIT A MIX DESIGN MEETING THE SPECIFICATION REQUIREMENTS FOR APPROVAL PRIOR TO PERFORMING THE WORK. OBTAIN 6 DRILLED CORE SPECIMENS FROM IN-PLACE SHOTCRETE FOR EACH DAY SHOTCRETE WORK IS PERFORMED IN ACCORDANCE WITH ASTM C1604. CORE SPECIMENS SHALL BE TESTED FOR 7, 14, AND 28 DAY COMPRESSIVE STRENGTHS OR UNTIL MINIMUM COMPRESSIVE STRENGTH IS REACHED. ALTERNATIVELY, CAST-IN-PLACE CONCRETE MAY BE PLACED IN LIEU OF SHOTCRETE. THE CONTRACTOR SHALL SUBMIT A MIX DESIGN FOR THE CAST-IN-PLACE CONCRETE AND MAKE TEST CYLINDERS IN ACCORDANCE WITH THE CONCRETE REQUIREMENTS OF NOTE 3.

PROCEDURES

- LOCATE ALL EXISTING UTILITIES BY UTILITY COMPANY MARK OUT, THEN, FOR UTILITIES WITHIN 5 FEET OF SOLDIER PILE INSTALLATION, CONFIRM CLEARANCE BY LOCAL PRE-EXCAVATION UP TO 5 FEET DEEP AT EACH SOLDIER PILE LOCATION.
- INSTALL HP SOLDIER PILES IN PRE-DRILLED CASED HOLE AS FOLLOWS:
 - DRILL A 24 INCH DIAMETER, OPEN ENDED, STEEL CASING TO TOP OF ROCK, REMOVING SOIL FROM WITHIN THE CASING USING AN AUGER. DRILL ROCK SOCKET TO THE LENGTH SHOWN ON THE THE DRAWINGS. EXTERNAL FLUSH METHODS ARE NOT BE PERMITTED. USE OF AN AIR POWERED DOWN HOLE HAMMER WILL NOT BE PERMITTED TO ADVANCE THE CASING THROUGH SOIL EXCEPT AS APPROVED BY THE ENGINEER TO PENETRATE OBSTRUCTIONS.
 - FILL CASED HOLE WITH AN EXCAVATABLE LEAN CONCRETE PLACED BY TREMIE METHOD.
 - IMMEDIATELY UPON FILLING, WITHDRAW THE STEEL CASING.
 - PUSH PILE INTO THE HOLE BEFORE THE LEAN CONCRETE STARTS SETTING. DRIVING OF THE PILE WILL NOT BE PERMITTED. ALTERNATIVELY, PILE MAY BE PLACED PRIOR TO CONCRETING PILE HOLE. PROVIDE CENTRALIZERS ON PILE AS REQUIRED TO MAINTAIN OUT-OF-PLUMBNESS UNDER 2%. PILES SHALL BE PLACED TO THE ORIENTATION SHOWN ON THE DRAWINGS.
 - THE LOCATION OF SOLDIER PILES AT ANY DEPTH ABOVE FINAL EXCAVATION SUBGRADE SHALL BE WITHIN ±3" OF ITS THEORETICAL PLAN LOCATION.
 - TOP OF SOLDIER PILE AND LAGGING WALL SHALL BE MINIMUM 1'-0" ABOVE GRADE BEHIND WALL.
- INSTALL SOLDIER PIPE PILES IN PRE-DRILLED CASED HOLE AS FOLLOWS:
 - INSTALL STEEL TEMPLATE AT GRADE TO ENSURE PILES ARE INSTALLED TANGENT TO PROPERTY LINE AS SHOWN ON THE DRAWINGS.
 - DRILL A 9-5/8 INCH DIAMETER, OPEN ENDED, STEEL CASING TO TOP OF ROCK, REMOVING SOIL FROM WITHIN THE CASING USING AN AUGER. SEAT CASING A MINIMUM OF 6 INCHES INTO ROCK AND DRILL ROCK SOCKET TO THE DEPTH SHOWN ON THE DRAWINGS. EXTERNAL FLUSH METHODS ARE NOT BE PERMITTED. USE OF AN AIR POWERED DOWN HOLE HAMMER WILL NOT BE PERMITTED TO ADVANCE THE CASING THROUGH SOIL EXCEPT AS APPROVED BY THE ENGINEER TO PENETRATE OBSTRUCTIONS.
 - CLEAN HOLE, INSERT REBAR AND PLACE GROUT BY TREMIE METHOD.
 - TOP OF SOLDIER PILE AND LAGGING WALL SHALL BE MINIMUM 1'-0" ABOVE GRADE BEHIND WALL.
 - PIPE THREADED JOINTS SHALL BE REINFORCED AS SHOWN ON THE DRAWINGS.
 - THE CONTRACTOR SHALL SUBMIT MEANS ND METHOD FOR DRILLING SOLDIER PIPE PILES THROUGH EXISTING FOUNDATION WALL TO THE ENGINEER FOR REVIEW PRIOR TO THE START OF WORK.
- TIEBACKS:
 - TIEBACKS SHALL BE DRILLED USING ROTARY DUPLEX DRILLING TECHNIQUES. SOILS SHALL BE REMOVED FROM WITHIN THE CASING USING WASH BORING METHODS, KEEPING THE WASH WATER RETURN INSIDE THE CASING. FLUSHING BEYOND THE CASING AND DRILLING TOOLS THAT RESULT IN CIRCULATION OUTSIDE OF THE CASING SHALL NOT BE USED. OTHER DRILLING METHODS THAT PREVENT GROUND LOSS SHALL BE PERMITTED SUBJECT TO THE ENGINEER'S APPROVAL.
 - TIEBACK GROUTING PRESSURE AND VOLUME SHALL BE DETERMINED BY THE TIEBACK CONTRACTOR TO ACHIEVE THE TIEBACK CAPACITIES SHOWN ON THESE DRAWINGS.
- EXCAVATION, DEWATERING AND BACKFILLING:
 - DO NOT EXCAVATE MORE THAN 2 FEET BEFORE INSTALLING TIMBER LAGGING. LEAVE 1-1/2" LOUVERS BETWEEN LAGGING BOARDS AND IMMEDIATELY BACKPACK VOIDS BEHIND THE LAGGING. WITHIN FIVE FEET OF THE SIDEWALK GRADE AND WHEN EXCAVATING BELOW THE PRECONSTRUCTION WATER TABLE, LINE LOUVERS WITH HAY OR FILTER FABRIC TO ALLOW DRAINAGE OF SURFACE RUNOFF AND GROUND WATER, WITHOUT SOIL LOSS.
 - DO NOT EXCAVATE MORE THAN TWO FEET BELOW CENTER LINE OF BRACING PRIOR TO INSTALLING THAT BRACING.
- UPON COMPLETION OF FOUNDATION CONSTRUCTION TO STREET GRADE:
 - PLACE COMPACTED BACKFILL BETWEEN SOLDIER PILE WALL AND FOUNDATION WALL, AND WITHIN THE EASEMENT LIMITS SOUTH OF THE PROPERTY LINE CONFORMING TO PROJECT SPECIFICATIONS. CUT TIEBACKS AFTER BACKFILLING HAS REACHED MINIMUM TWO FEET BELOW THE LEVEL OF BRACING TO BE REMOVED.
 - ALL SOLDIER PILES SHALL BE CUT AND REMOVED TO 4 FEET BELOW SIDEWALK GRADE.
 - ALL TIMBER LAGGING AND SOLDIER PILES BELOW 4 FEET SHALL REMAIN IN PLACE.

SURVEY AND MONITORING

- THE OWNER WILL PERFORM A PRE-CONSTRUCTION BUILDING CONDITION SURVEY OF THE ADJACENT BUILDINGS. COPIES WILL BE AVAILABLE FOR THE CONTRACTOR'S INFORMATION UPON REQUEST.
- THE OWNER'S GEOTECHNICAL INSTRUMENTATION ENGINEER (GIE) WILL IMPLEMENT A MONITORING AND INSTRUMENTATION PROGRAM DURING CONSTRUCTION FOR PROTECTION OF ADJACENT STRUCTURES. THESE MONITORING POINTS ARE SHOWN ON SOE DRAWINGS. THRESHOLD AND LIMITING VALUES FOR MOVEMENTS AND VIBRATIONS OF ADJACENT STRUCTURES DURING THE CONSTRUCTION ARE AS INDICATED BELOW. THE CONTRACTOR SHALL UTILIZE CONSTRUCTION METHODS THAT MINIMIZE MOVEMENTS AND VIBRATIONS, WHICH IN NO CASE SHALL EXCEED THE SPECIFIED CRITERIA.
- THE OWNER'S GIE WILL PROVIDE MONITORING OF SURVEY POINTS AND VIBRATIONS, AND WILL PROVIDE DATA ACCESS ON A WEBSITE PLUS ALARM NOTIFICATION VIA EMAIL TO A DISTRIBUTION LIST OF RECIPIENTS. THE CONTRACTOR SHALL DESIGNATE AN ON-SITE POINT OF CONTACT FOR SUCH CORRESPONDENCE WHO SHALL REMAIN AVAILABLE TO RESPOND TO ALARMS THROUGHOUT CONSTRUCTION AND WHO HAS THE AUTHORITY TO DIRECT SITE ACTIVITIES AS MAY BE REQUIRED SHOULD MOVEMENT OR VIBRATION CRITERIA BE EXCEEDED.
- PRIOR TO THE START OF THE EXCAVATION, SOE AND UNDERPINNING WORK, THE CONTRACTOR SHALL PROVIDE A SURVEY OF AS-BUILT X, Y, Z COORDINATES OF MONITORING PRISMS INSTALLED BY THE GIE ON THE PROJECT COORDINATE SYSTEM.
- THE CONTRACTOR SHALL PROVIDE THE GIE ACCESS TO THE SITE AND COOPERATE WITH HIM IN HIS MONITORING AND INSTRUMENTATION DUTIES. THE CONTRACTOR SHALL, AT THE GIE'S REQUEST, PROVIDE AN EXTENSION LADDER AND LABOR, OR OTHER EQUIPMENT/LABOR AS REQUIRED FOR INSTALLATION, MAINTENANCE AND REMOVAL OF PRISMS AND OTHER MONITORING EQUIPMENT.
- BUILDING MOVEMENT AND VIBRATION CRITERIA:
 - IF BUILDING MOVEMENT EXCEEDS 1/4" (THRESHOLD VALUE) ABOVE BASELINE READINGS, THE CONSTRUCTION MANAGER WILL MEET WITH THE CONTRACTOR AND ENGINEER TO REVIEW CONSTRUCTION PROCEDURES AND ESTABLISH COURSE OF ACTION TO MINIMIZE FUTURE ADDITIONAL MOVEMENTS.
 - IF BUILDING MOVEMENT REACHES 1/2" (LIMITING VALUE) ABOVE BASELINE READINGS, THE CONTRACTOR SHALL IMMEDIATELY STOP WORK, EXCEPT FOR THAT WORK DEEMED NECESSARY TO STABILIZE CONDITIONS, AND SUBMIT REVISED WORK PROCEDURES AND A REMEDIATION PLAN, IF REQUIRED, TO THE CONSTRUCTION MANAGER. WORK SHALL NOT RESUME UNTIL APPROVED BY THE CONSTRUCTION MANAGER.
 - SOLDIER PILES MOVEMENT CRITERIA IS 0.75" THRESHOLD VALUE AND 1.5" LIMITING VALUE WITH THE SAME ACTION RESPONSE REQUIREMENTS AS PROVIDED FOR BUILDING MOVEMENTS.
 - IF THE VIBRATION MONITORING PEAK PARTICLE VELOCITY (PPV) EXCEEDS 0.5 INCH PER SECOND (IPS) (THRESHOLD VALUE), THE CONTRACTOR SHALL MODIFY HIS PROCEDURES TO MINIMIZE THRESHOLD VALUES FROM BEING EXCEEDED IN THE FUTURE.
 - IF THE VIBRATION MONITORING PPV EXCEEDS 2 IPS (LIMITING VALUE), IMMEDIATELY STOP WORK. WORK SHALL RESUME UPON THE APPROVAL BY THE CONSTRUCTION MANAGER. REVISED WORK PROCEDURES MAY BE REQUIRED.

LIST OF REQUIRED NYC DOB SPECIAL INSPECTIONS:

- EXCAVATION - SHEETING, SHORING AND BRACING
- STRUCTURAL STABILITY - EXISTING BUILDINGS
- SUBSURFACE CONDITIONS - FILL PLACEMENT AND IN-PLACE DENSITY

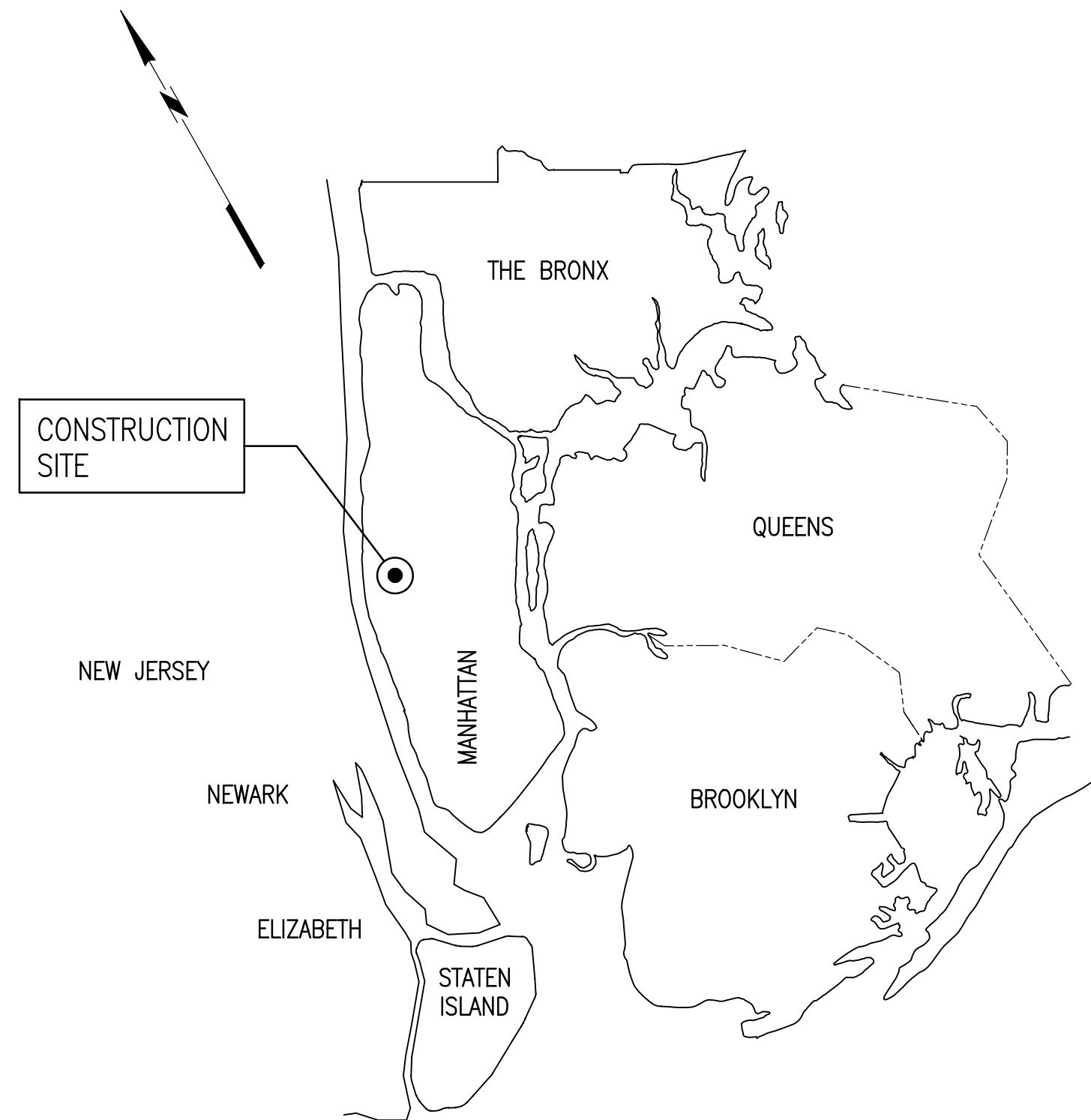

VICINITY MAP
SCALE: NO SCALE

LIST OF DRAWINGS

DRAWING NUMBER	DRAWING TITLE
SOE-100	SUPPORT OF EXCAVATION GENERAL NOTES
SOE-101	EXISTING SITE SURVEY
SOE-102	SUPPORT OF EXCAVATION LAYOUT PLAN
SOE-103	SUPPORT OF EXCAVATION SECTIONS
SOE-104	SUPPORT OF EXCAVATION DETAILS AND SECTIONS 1 OF 2
SOE-105	SUPPORT OF EXCAVATION DETAILS AND SECTIONS 2 OF 2

PROJECT NUMBER: MRCE #12509

DATE: 12-08-2016

REVISIONS:

NO.	DESCRIPTION	DATE
1	DOB FILING	09-26-16
2	BD SET	10-10-16
3	CONSTRUCTION DOCUMENTS	11-01-16
4	100% CONSTRUCTION DOCUMENTS	12-08-16

SCALE: AS NOTED

DRAWING NAME:

SUPPORT OF EXCAVATION
GENERAL NOTES

DRAWING NUMBER: Ref. North

DRAWING NUMBER:

SOE-100.00

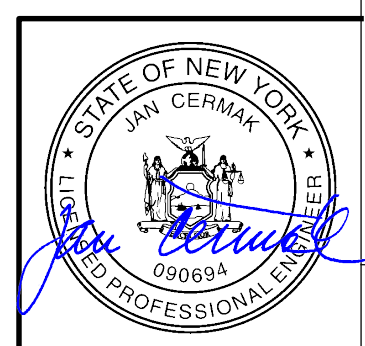

Owner/ Developer
Amsterdam Avenue
Redevelopment Associates, LLC
c/o SJP Residential Properties
Eleven Times Square
New York, NY 10036

Architect
Elkus Manfredi Architects
25 Drydock Avenue
Boston, MA 02210

Interior Architect
Cetra Ruddy
584 Broadway, Suite 401
New York, NY USA 10012

Structural Engineer
DeSimone Consulting Engineers
140 Broadway, 25th Floor
New York, NY 10011

MEP/FP Engineer
AKF Group
One Liberty Plaza
165 Broadway, 22 Floor
New York, New York 10006

Geotechnical Engineer
Mueser Rutledge
225 West 34th Street, 10th Floor
New York, NY 10122

Civil Engineer
Stonefield Engineering & Design LLC
75 Orient Way, Suite 303
Rutherford, NJ 07070

Building Envelope Consultant
Vidaris, Inc.
360 Park Avenue South, 15 Floor
New York, NY 10010

Facade Maintenance Consultant
Entek Engineering, LLC
Hackensack, NJ 07601
160 Ames Street

Vertical Transportation Consultant
Joseph Neto & Associates
1430 Broadway, Suite 908
New York, New York 10006

Acoustics Consultant
Longman Lindsey
1410 Broadway, Suite 508
New York, NY 10018

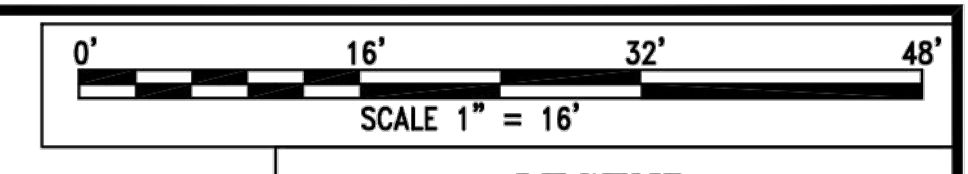

LEGEND	
FF	FIRST FLOOR ELEVATION
CF	CELLAR FLOOR ELEVATION
EL	SPOT ELEVATION
PI	POINT OF INTERSECTION
TC	TOP OF CURB
BC	BOTTOM OF CURB
CL	CENTERLINE
EL	SPOT ELEVATION
CONC	CONCRETE
INV	INVERT ELEVATION
(E)	ELECTRIC MANHOLE
(W)	WATER MANHOLE
(L)	LIGHT POLE
(S)	SEWER MANHOLE
(MP)	MUNICIPAL PARKING METER
(W)	WATER VALVE
(G)	GAS VALVE
(GR)	GRATING
(C)	CURB CUT
(X)	IRON FENCE
(-x-x-)	CHAIN LINK FENCE
(- - -)	PROPERTY LINE

JUNE 2, 2016	ELEVATION ADDED TO CELLAR FLOOR
MARCH 30, 2016	LOCATION OF SOUTH & WEST CELLAR WALLS
DATE	DESCRIPTION
SHEET 1 OF 1	JOB NUMBER: SF2047
PROPERTY SITUATED AT: 200 AMSTERDAM AVENUE BOROUGH OF MANHATTAN COUNTY OF NEW YORK CITY & STATE OF NEW YORK	TAX BLOCK: 1158 TAX LOT: 133

Ramzan Alli License No. 050457
NY Land Surveyor P.C.
77-15 164th Street
Fresh Meadows, NY 11366
Tel. (718) 591-6600 Fax (718) 591-7954
Fax (631) 930-3292
nylandsurveyor@gmail.com

NOTE:
ELEVATIONS REFER TO NORTH AMERICAN VERTICAL DATUM 1998 (NAVD88).
INFORMATION PERTAINING TO WATER MAINS AND SEWER LINES HAS BEEN FURNISHED BY THE DEPARTMENT OF ENVIRONMENTAL PROTECTION AND IS PLACED ON THE DRAWING FOR SCHEMATIC PURPOSE ONLY AND DOES NOT, AND IS NOT INTENDED TO INDICATE LOCATION, DEPTH, SIZE, CONNECTION BOXES OR HOUSE CONNECTIONS. THIS INFORMATION IS NOT GUARANTEED AS TO CORRECTNESS, ACCURACY OF COMPLETENESS BY THEM NOR BY EARL B. LOVELL - S.P. BELCHER, INC. MANHOLE COVERS HAVE BEEN PLOTTED FROM FIELD MEASUREMENTS. SEWER DEPTH ARE AS FIELD MEASURED.

CAUTION:
BEFORE DOING ANY EXCAVATION OR DRILLING ON THIS SITE, IT IS REQUIRED THAT SUBSURFACE SERVICE, INCLUDING THE UNDERGROUND MAINS, DUCTS AND CABLE BE MARKED AND IDENTIFIED BY THE UTILITY INVOLVED, THIS SHOULD BE DONE BY PROVIDING THE AFFECTED UTILITY WITH THE NOTICE REFERRED TO IN THE STATE OF NEW YORK INDUSTRIAL CODE 53.

THIS IS TO CERTIFY THAT THERE ARE NO STREAMS OR NATURAL WATER COURSES VISIBLE ON THE PROPERTY SHOWN ON THIS SURVEY.

THIS IS TO CERTIFY THAT THIS SITE DOES NOT LIE WITHIN A FLOOD HAZARD AREA AS DESIGNATED BY THE FEDERAL EMERGENCY MANAGEMENT AGENCY

UTILITIES ENTERING BUILDING ADDED DECEMBER 18, 2015
ADDITIONAL INFORMATION ADDED NOVEMBER 24, 2015
ENCROACHMENTS IF ANY BELLOW SURFACE NOT SHOWN HERE ON SURVEYED MARCH 28, 2014
EARL B. LOVELL - S.P. BELCHER, INC.

PROJECT NUMBER: MRCE #12509

DATE: 12-08-2016

REVISIONS:

DOB FILING	09-26-16
BD SET	10-10-16
CONSTRUCTION DOCUMENTS	11-01-16
100% CONSTRUCTION DOCUMENTS	12-08-16

SCALE: AS NOTED

DRAWING NAME:
EXISTING SITE SURVEY

DRAWING NUMBER:

SOE-101.00

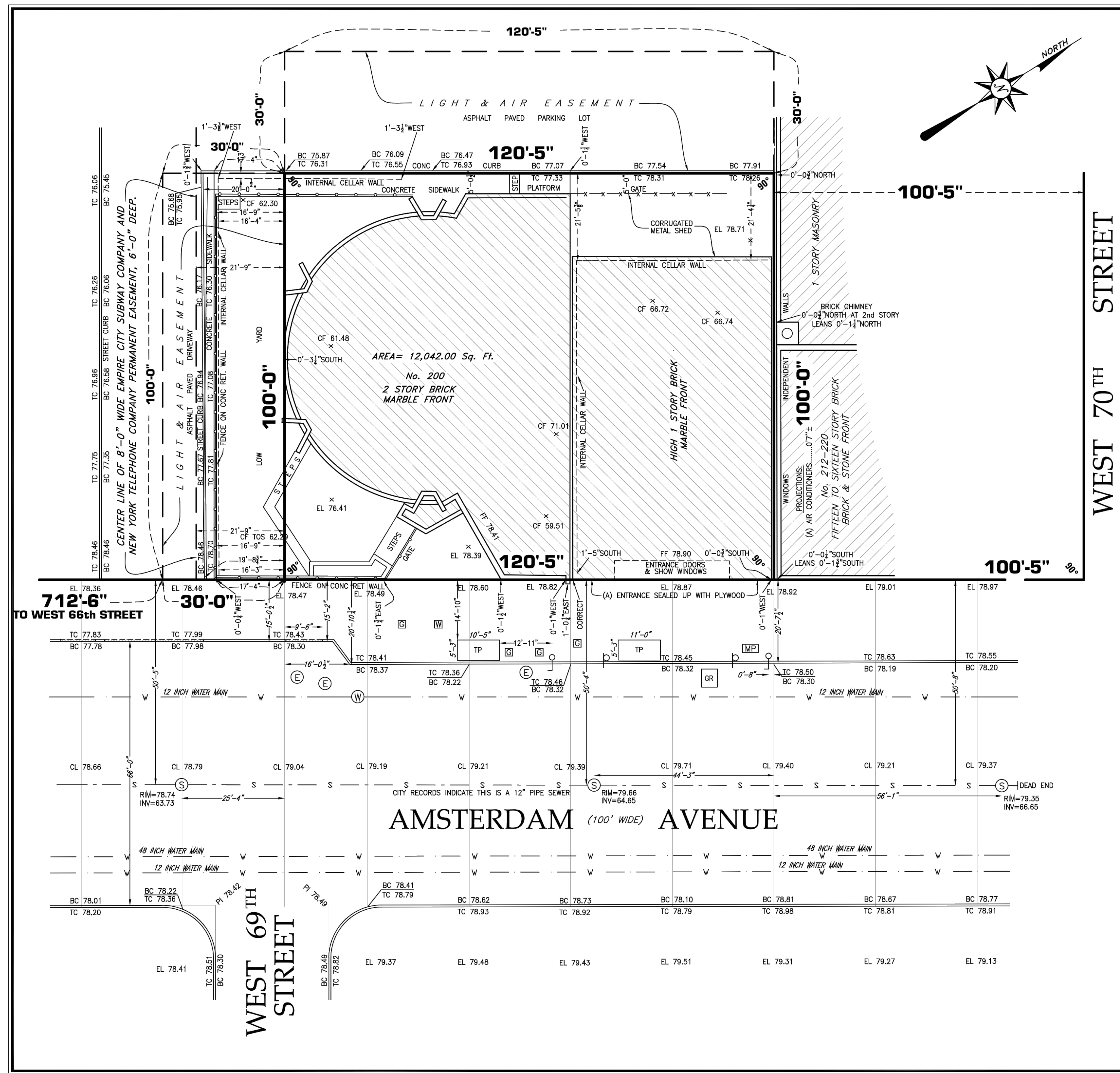
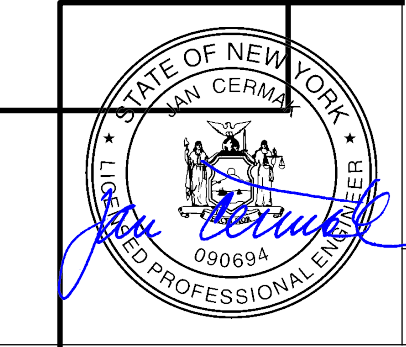
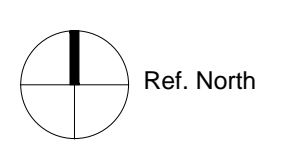

REVISIONS:

DOB FILING	09-26-16
BID SET	10-10-16
CONSTRUCTION DOCUMENTS	11-01-16
100% CONSTRUCTION DOCUMENTS	12-08-16

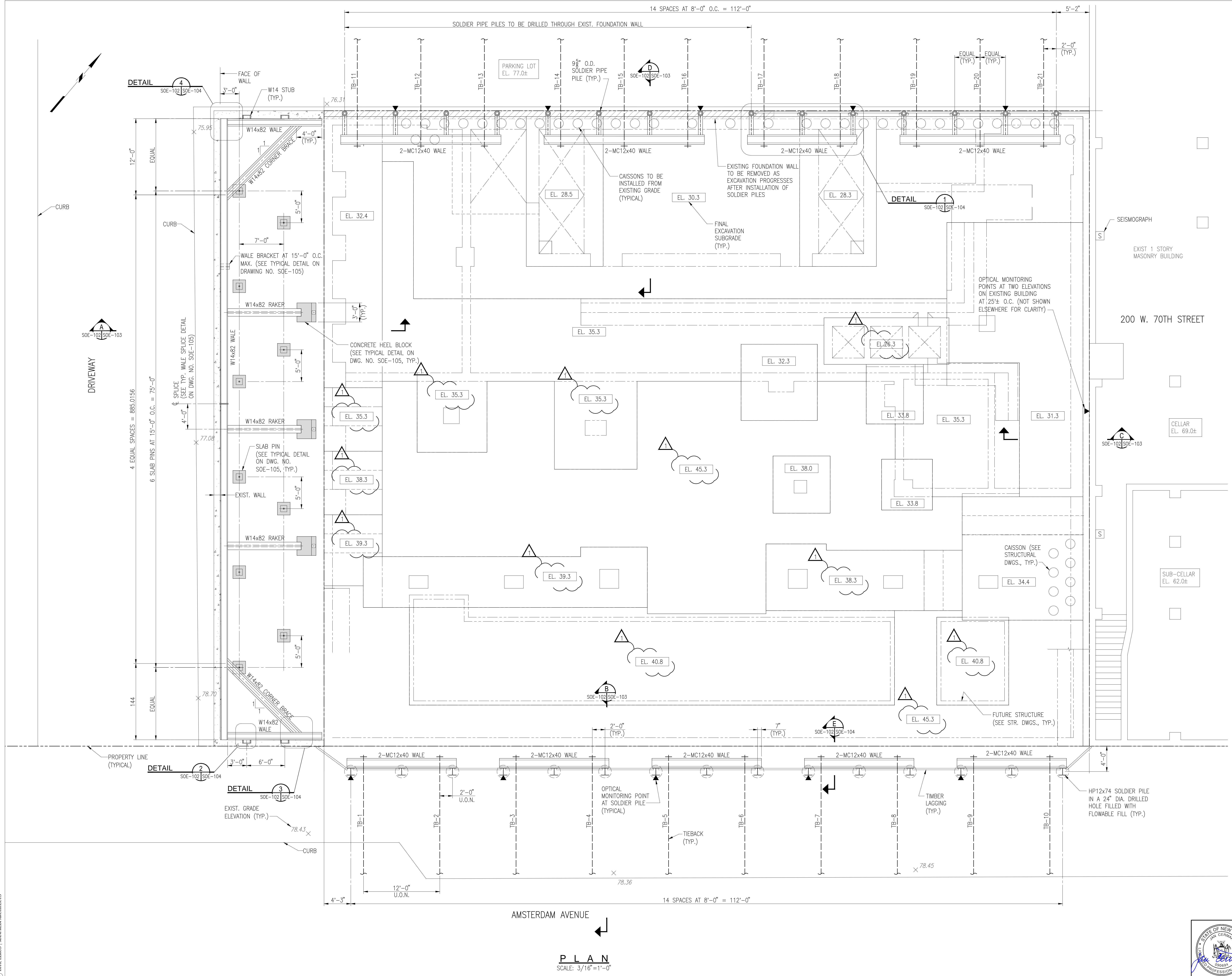

PLAN
SCALE: 3/16" = 1'-0"

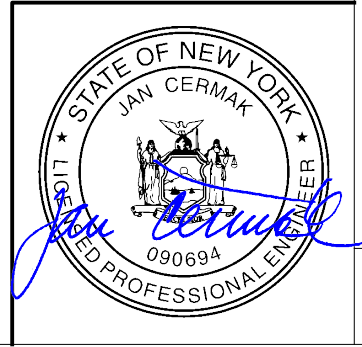

PROJECT NUMBER: MRCE #12509

DATE: 12-08-2016

REVISIONS:

DOB FILING	09-26-16
BD SET	10-10-16
CONSTRUCTION DOCUMENTS	11-01-16
100% CONSTRUCTION DOCUMENTS	12-08-16

SCALE: AS NOTED

DRAWING NAME:

SUPPORT OF EXCAVATION SECTIONS

Ref. North

DRAWING NUMBER:

SOE-103.00

NOTES:

- ROCK FACE SHALL BE STABILIZED WITH ROCK BOLTS AS SHOWN ON THE SECTIONS. ADDITIONAL ROCK BOLTS SHALL BE INSTALLED AS DETERMINED BY THE ENGINEER IN THE FIELD. WHERE LOOSE OR HIGHLY FRACTURED ROCK IS ENCOUNTERED, THE ROCK FACE SHALL BE STABILIZED WITH REINFORCED SHOTCRETE OR C.I.P. CONCRETE AS SHOWN ON THE TYPICAL DETAIL ON DRAWING NO. SOE-105.
- CONTRACTOR SHALL INSPECT THE EXISTING RETAINING WALL ALONG THE EASEMENT IN THE PRESENCE OF THE ENGINEER TO DETERMINE IF SUPPORT IS REQUIRED PRIOR TO PROCEEDING WITH EXCAVATION. IF REQUIRED, THE CONTRACTOR SHALL IMPLEMENT SUPPORT DETAILS DEVELOPED BY THE ENGINEER.
- PRIOR TO PROCEEDING WITH ROCK EXCAVATION IN FRONT OF HP12 SOLDIER PILES, AS SHOWN ON SECTION B, INSTALL TOE ANCHOR AT EACH PILE. TORCH 4 INCH DIAMETER HOLE ON PILE FLANGES AND DRILL ANCHOR 15 FEET INTO ROCK USING A 4" DIAMETER DRILL BIT. FILL GROUT HOLE WITH 4000 PSI GROUT. WASHER, BEVEL PLATES AND NUTS SHALL BE AS PER MANUFACTURER RECOMMENDATIONS.

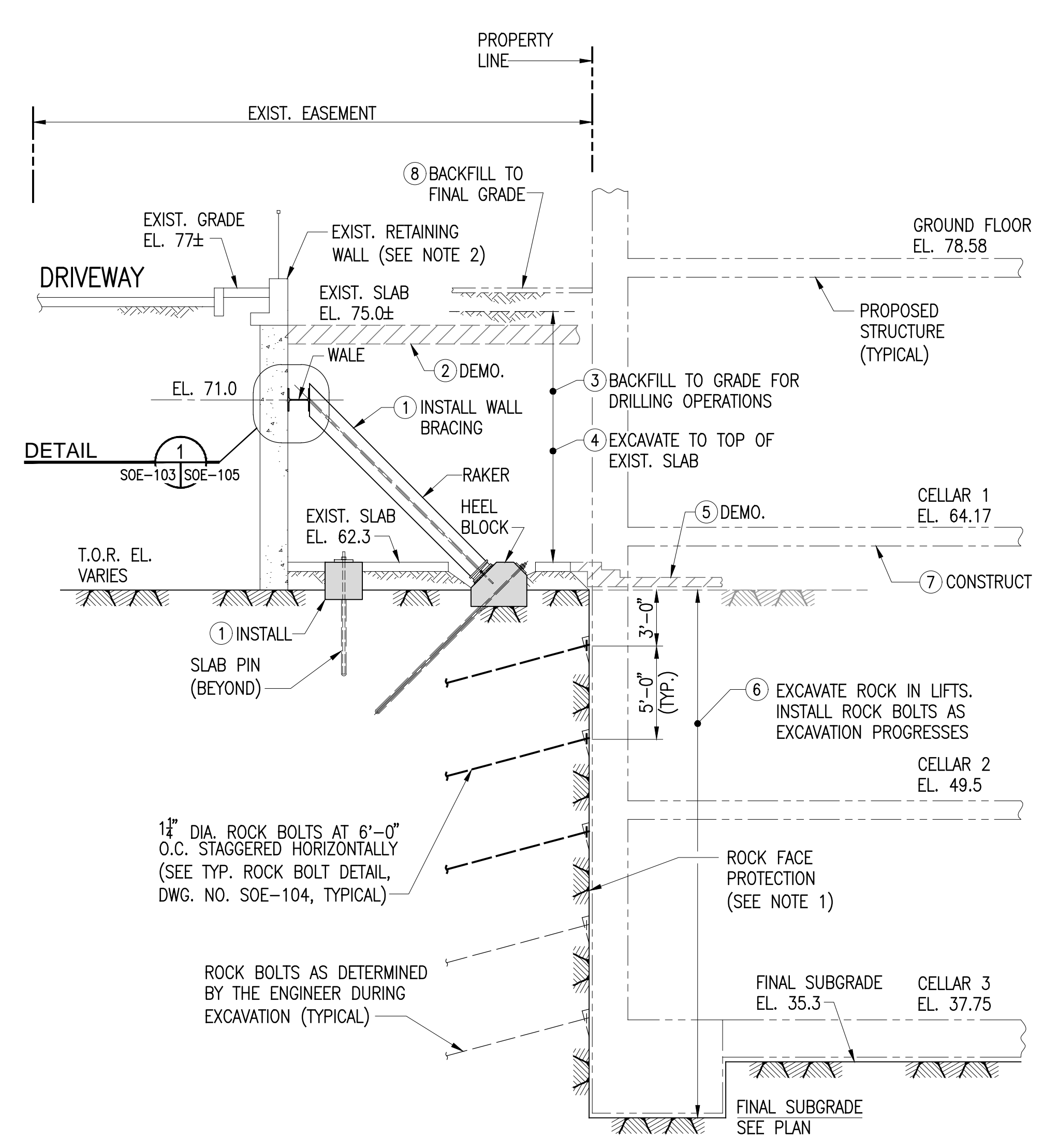

SECTION A
SCALE: 3/16"=1'-0" SOE-102|SOE-103

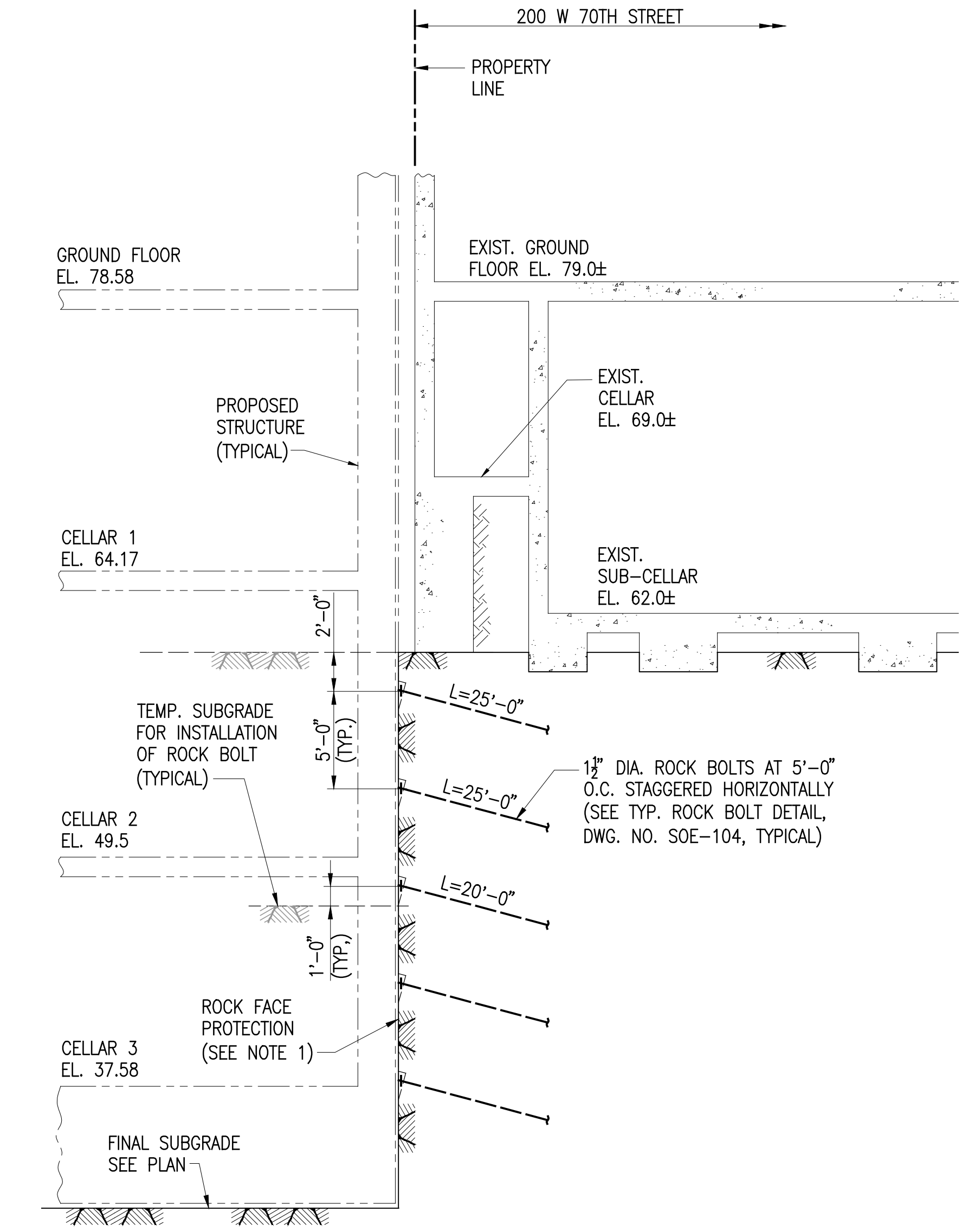

SECTION C
SCALE: 3/16"=1'-0" SOE-102|SOE-103

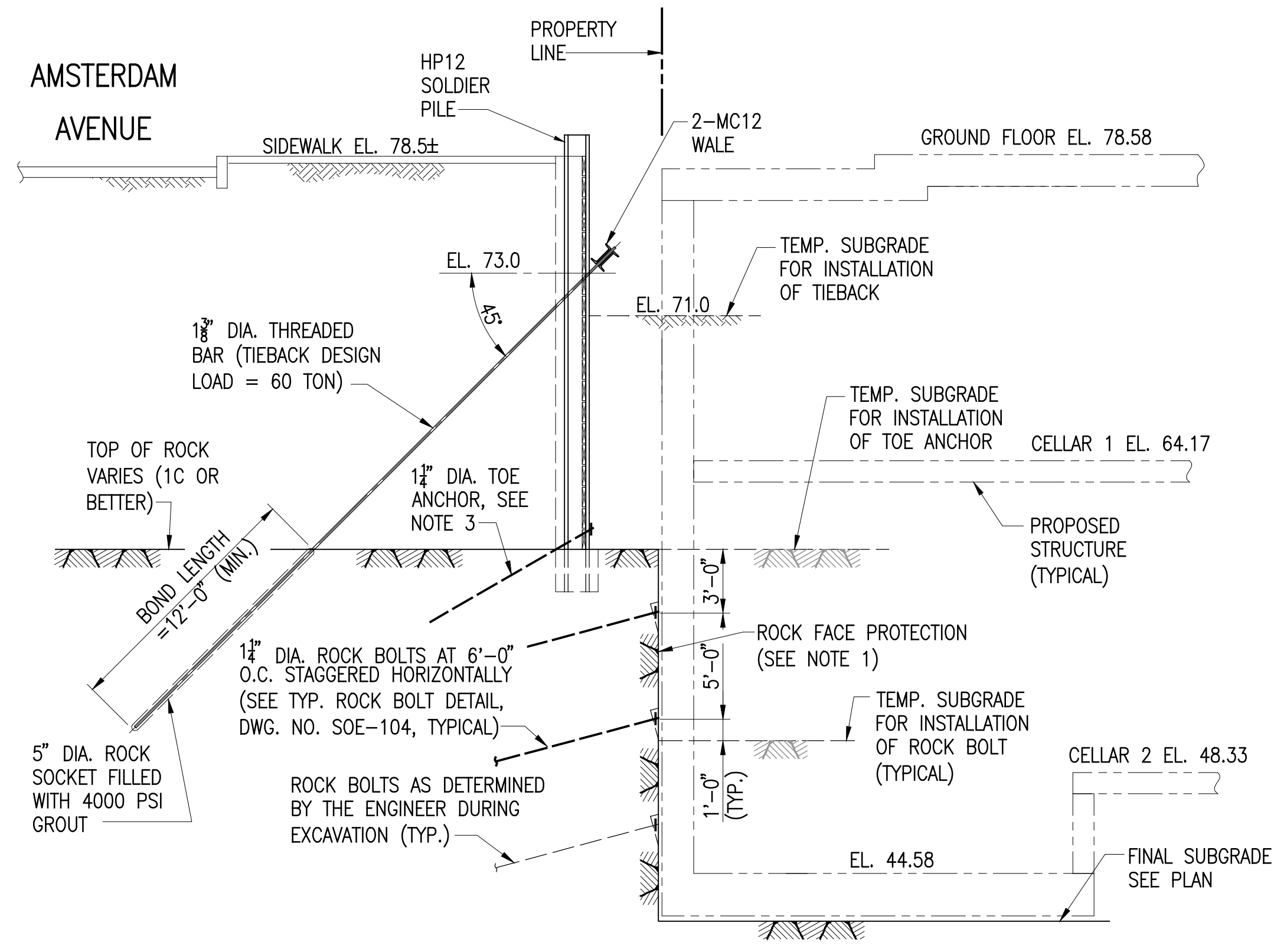

SECTION B
SCALE: 3/16"=1'-0" SOE-102|SOE-103

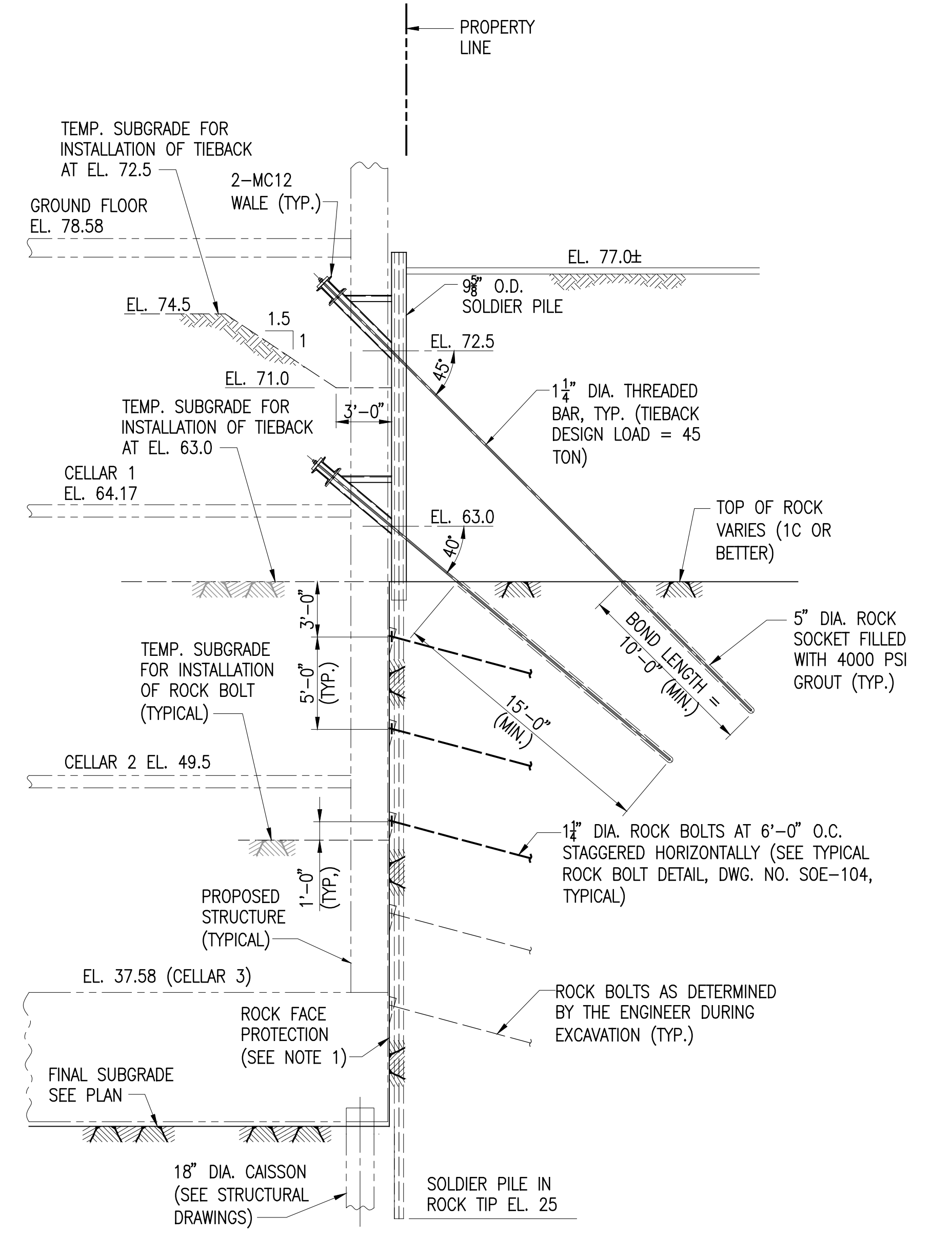

SECTION D
SCALE: 3/16"=1'-0" SOE-102|SOE-103

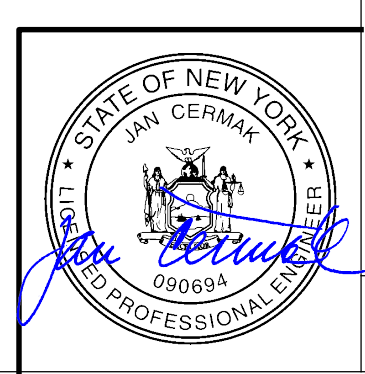

Owner/ Developer
Amsterdam Avenue
Redevelopment Associates, LLC
c/o SJP Residential Properties
Eleven Times Square
New York, NY 10036

Architect
Elkus Manfredi Architects
25 Drydock Avenue
Boston, MA 02210

Interior Architect
Cetra Ruddy
584 Broadway, Suite 401
New York, NY USA 10012

Structural Engineer
DeSimone Consulting Engineers
140 Broadway, 25th Floor
New York, NY 10011

MEP/ FP Engineer
AKF Group
One Liberty Plaza
165 Broadway, 22 Floor
New York, New York 10006

Geotechnical Engineer
Mueser Rutledge
225 West 34th Street, 10th Floor
New York, NY 10122

Civil Engineer
Stonefield Engineering & Design LLC
75 Orient Way, Suite 303
Rutherford, NJ 07070

Building Envelope Consultant
Vidaris, Inc.
360 Park Avenue South, 15 Floor
New York, NY 10010

Facade Maintenance Consultant
Entek Engineering, LLC
Hackensack, NJ 07601
160 Ames Street

Vertical Transportation Consultant
Joseph Neto & Associates
1430 Broadway, Suite 908
New York, New York 10006

Acoustics Consultant
Lognan Lindsey
1410 Broadway, Suite 508
New York, NY 10018

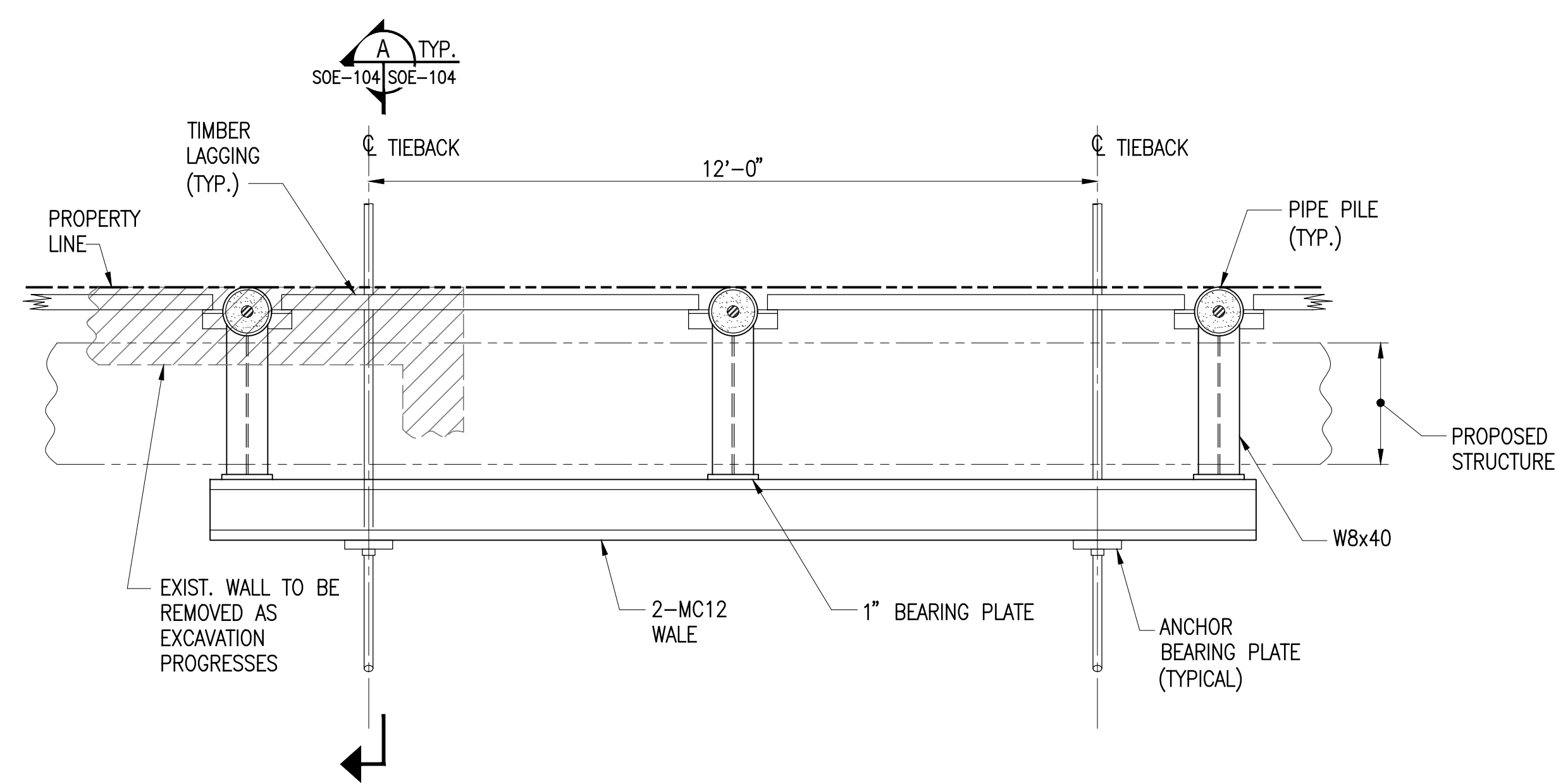

DETAIL 1
SCALE: 1/2"=1'-0" SOE-102|SOE-104

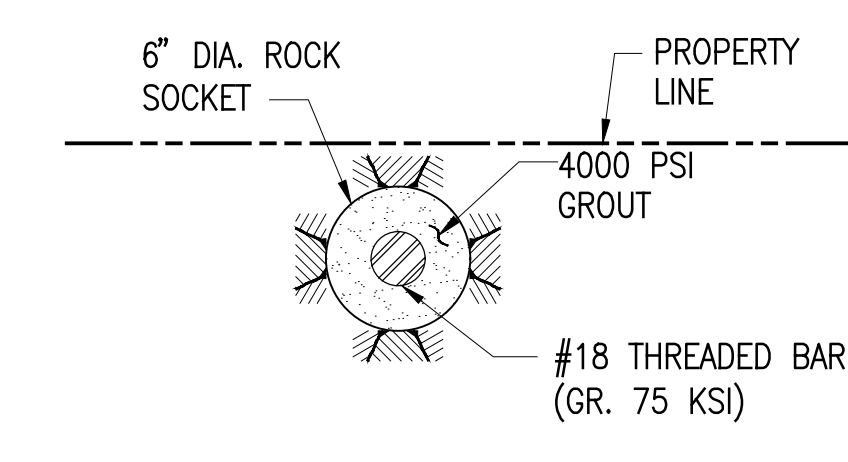
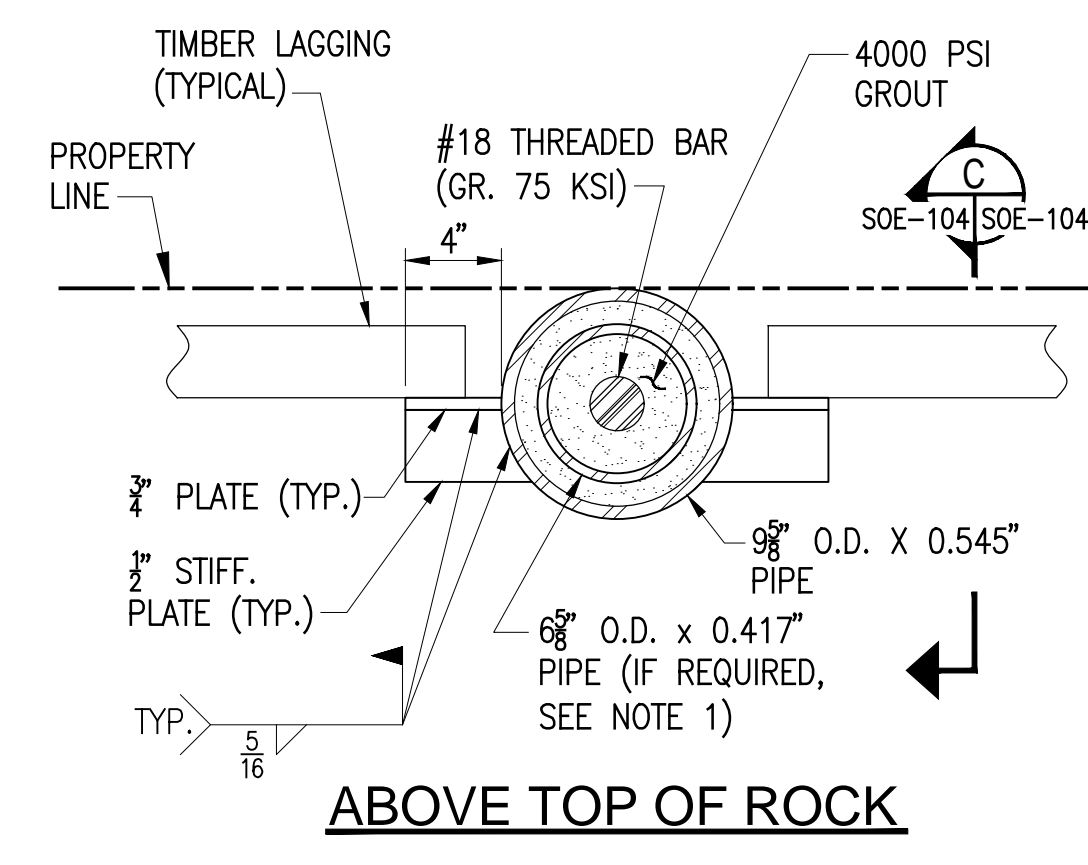

ABOVE TOP OF ROCK
BELOW TOP OF ROCK

TYPICAL PIPE PILE AND LAGGING DETAIL
SCALE: 1-1/2"=1'-0"

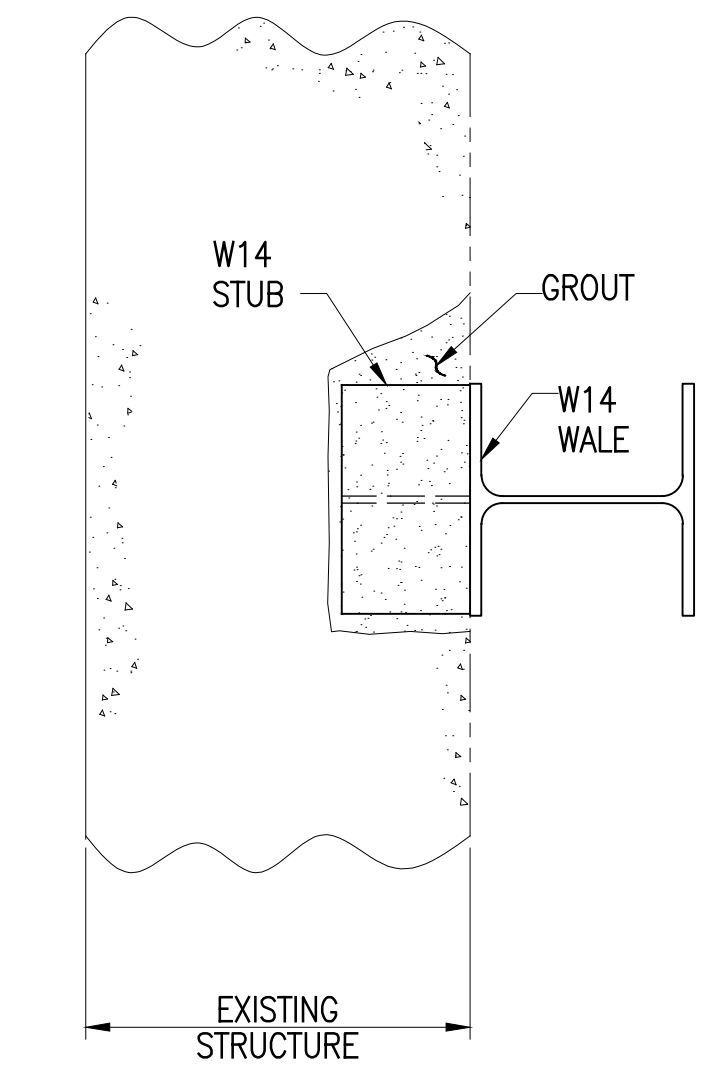

SECTION B
SCALE: 1"=1'-0" SOE-104|SOE-104

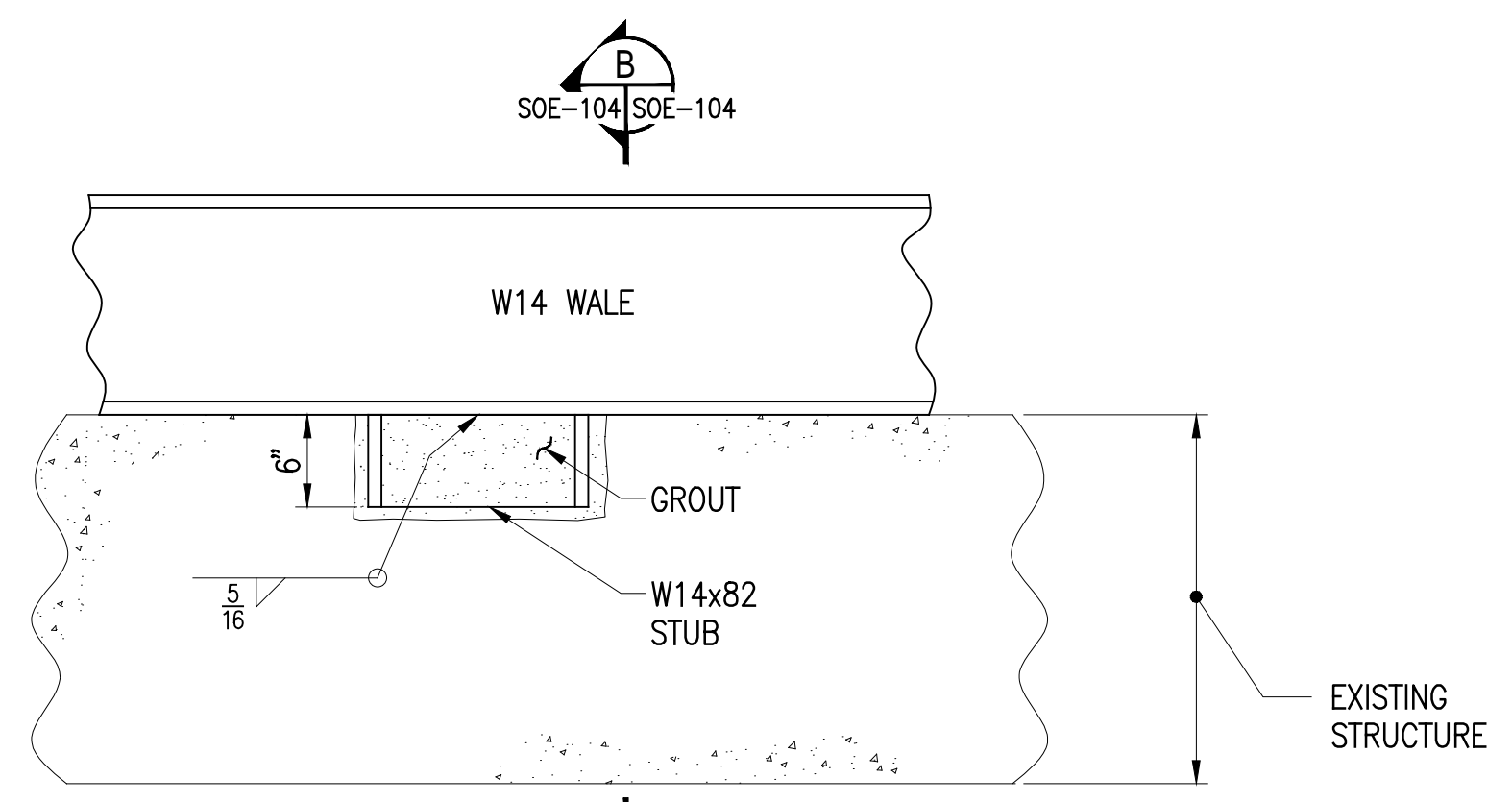

DETAIL 2
SCALE: 1"=1'-0" SOE-102|SOE-104

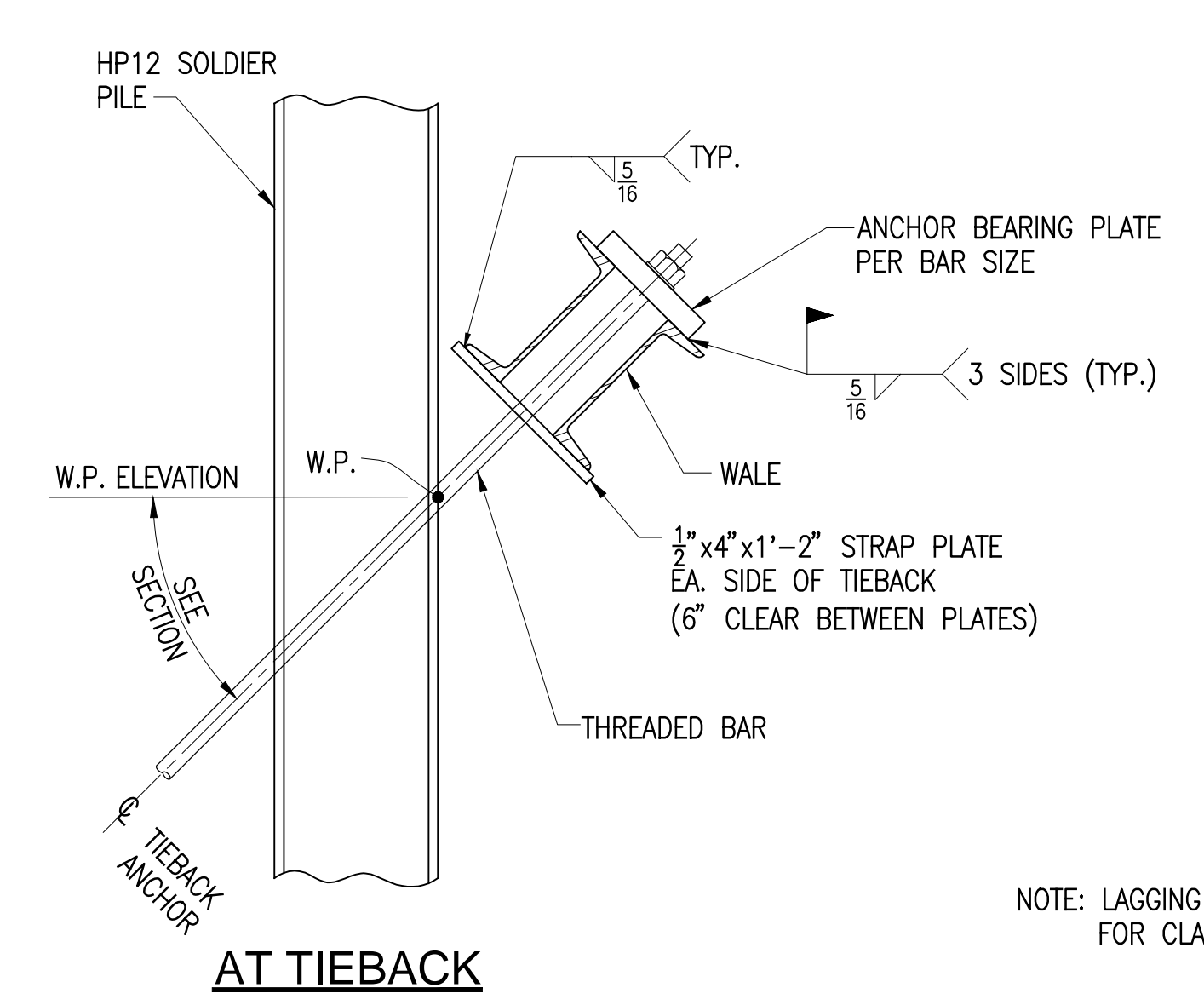

NOTE: LAGGING NOT SHOWN FOR CLARITY

SECTION E
SCALE: 1"=1'-0" SOE-102|SOE-104

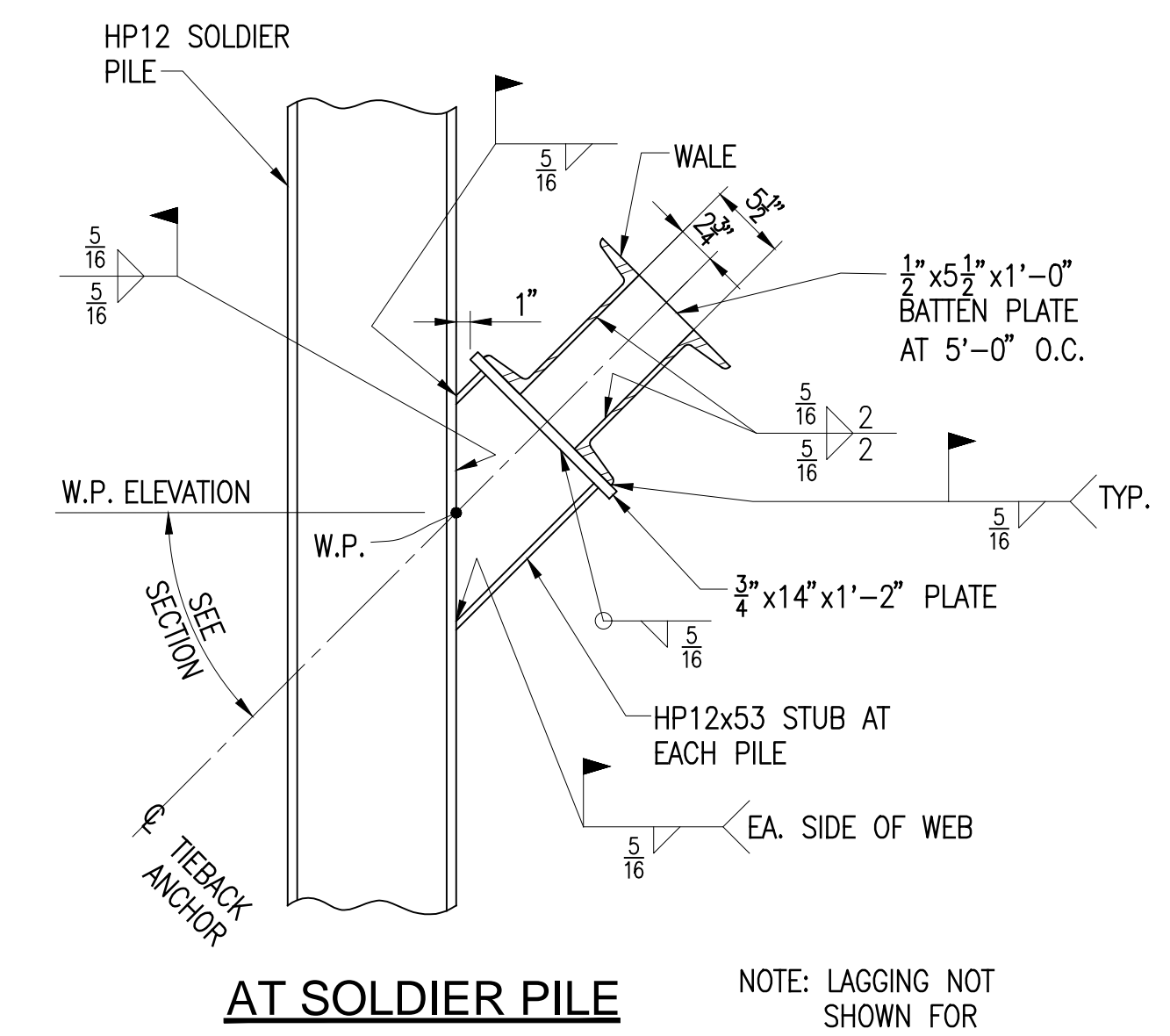

NOTE: LAGGING NOT SHOWN FOR CLARITY

SECTION E
SCALE: 1"=1'-0" SOE-102|SOE-104

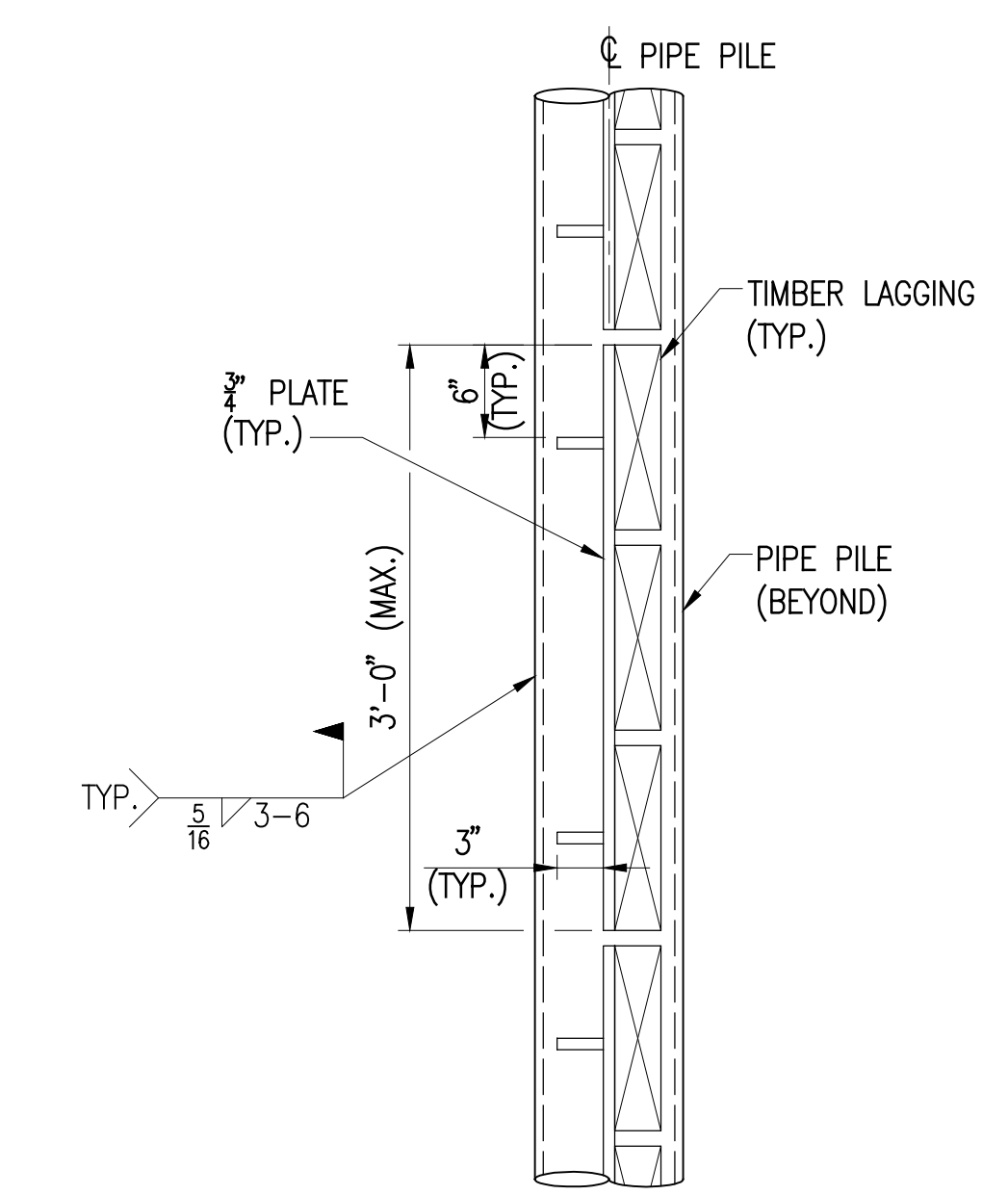

SECTION C
SCALE: 1"=1'-0" SOE-104|SOE-104

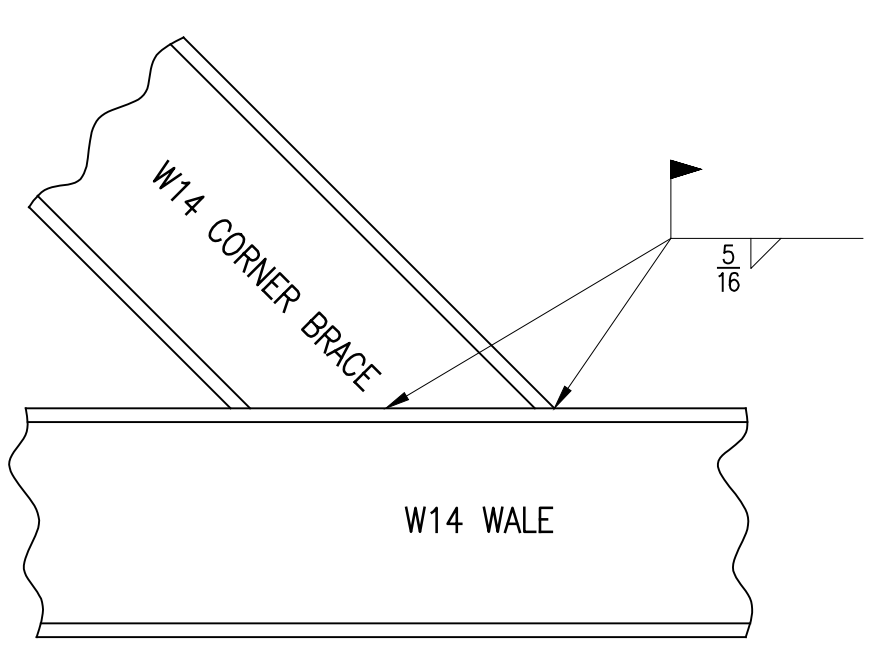

DETAIL 3
SCALE: 1"=1'-0" SOE-102|SOE-104

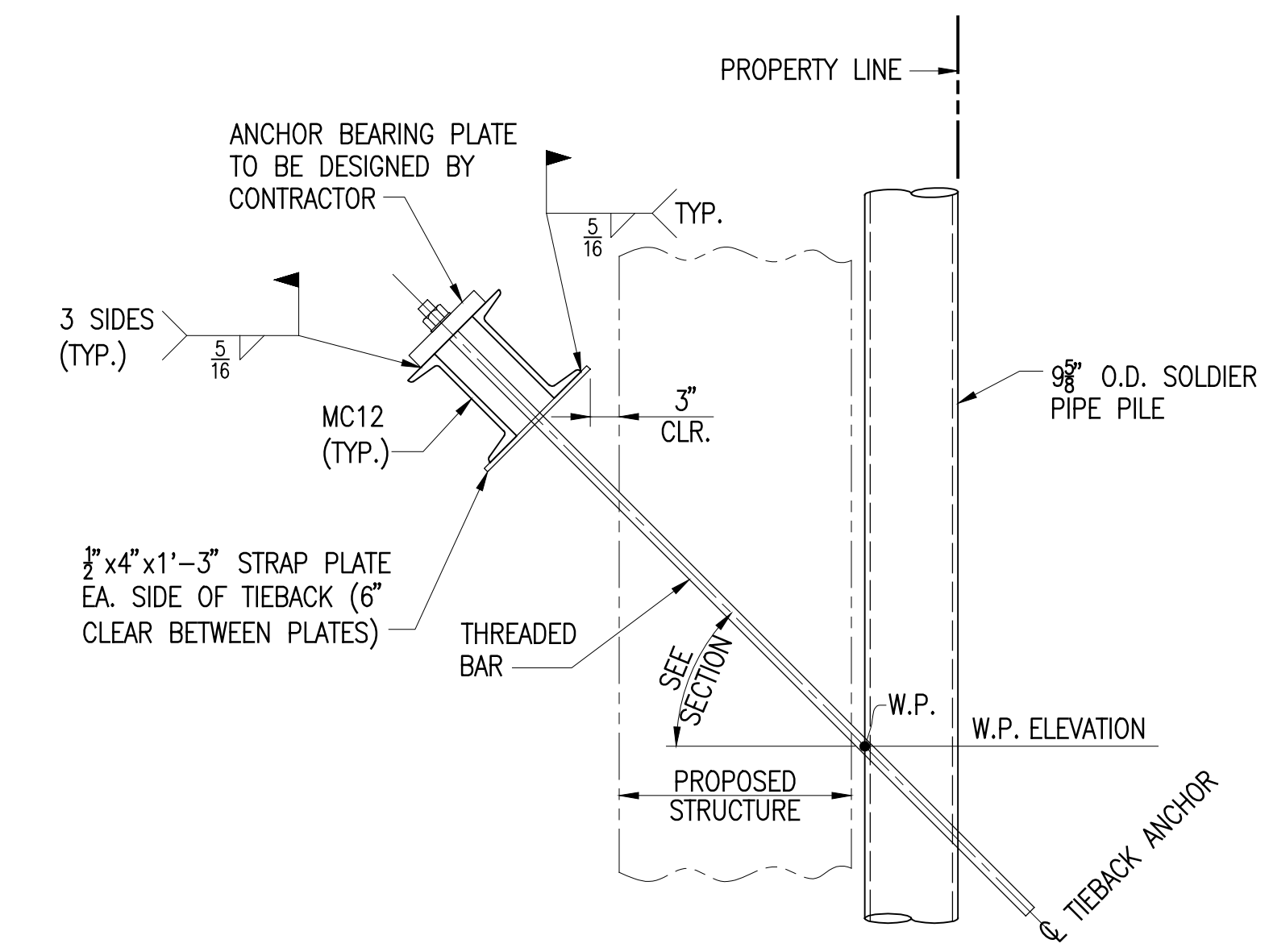

NOTE: LAGGING NOT SHOWN FOR CLARITY

SECTION A
SCALE: 3/4"=1'-0" SOE-104|SOE-104

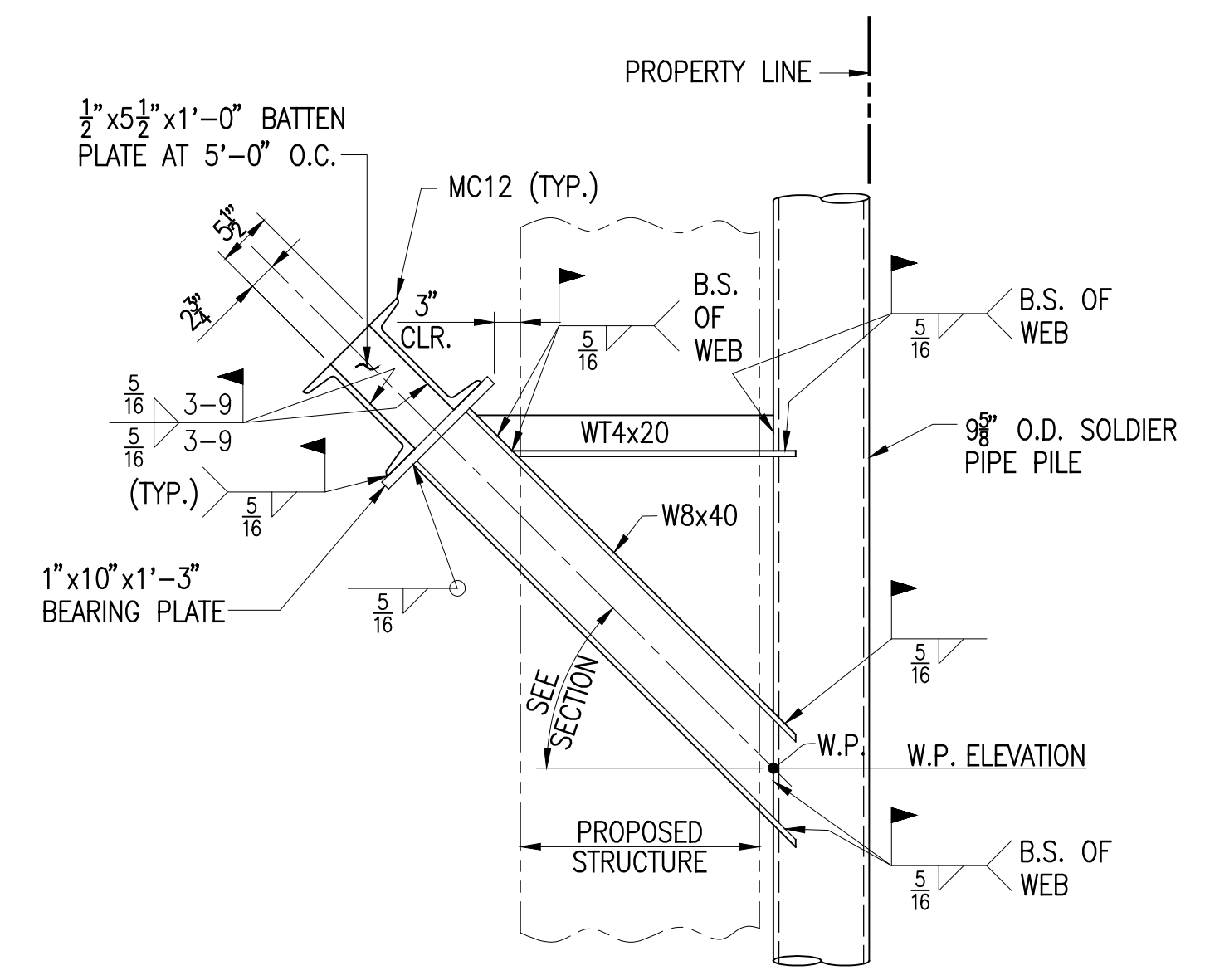

SECTION A
SCALE: 3/4"=1'-0" SOE-104|SOE-104

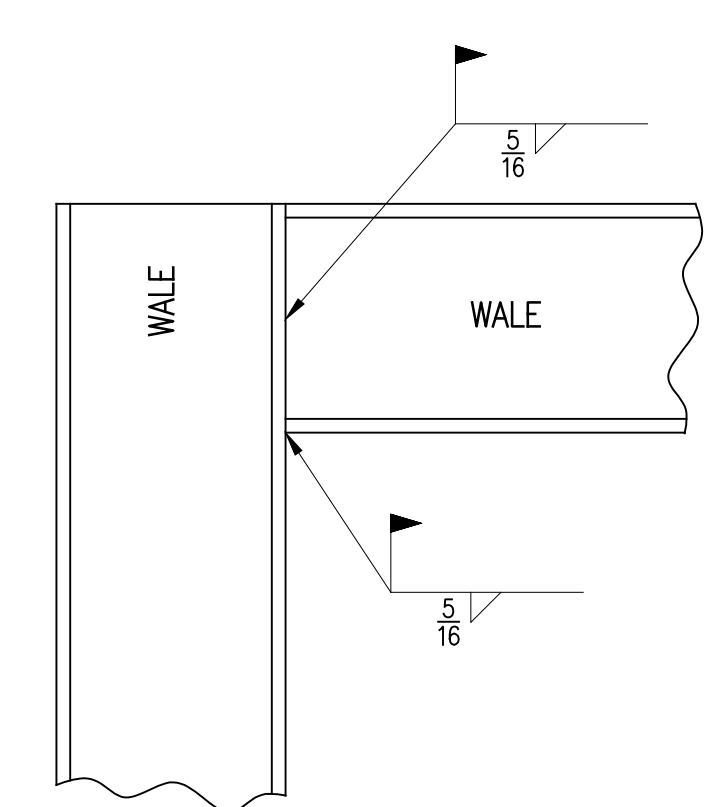

DETAIL 4
SCALE: 1"=1'-0" SOE-102|SOE-104

- NOTES:
- PIPE PILES THREADED JOINTS (IF APPLICABLE) SHALL BE REINFORCED WITH A 6" O.D. INNER PIPE, 10' LONG, CENTERED ABOUT JOINT.

PROJECT NUMBER: MRCE #12509

DATE: 12-08-2016

REVISIONS:

DOB FILING	09-26-16
BD SET	10-10-16
CONSTRUCTION DOCUMENTS	11-01-16
100% CONSTRUCTION DOCUMENTS	12-08-16

SCALE: AS NOTED

DRAWING NAME:

SUPPORT OF EXCAVATION DETAILS
2 OF 2

Ref. North

DRAWING NUMBER:

SOE-104.00



Owner/ Developer
Amsterdam Avenue
Redevelopment Associates, LLC
c/o SJP Residential Properties
Eleven Times Square
New York, NY 10036

Architect
Elkus Manfredi Architects
25 Drydock Avenue
Boston, MA 02210

Interior Architect
Cetra Ruddy
584 Broadway, Suite 401
New York, NY USA 10012

Structural Engineer
DeSimone Consulting Engineers
140 Broadway, 25th Floor
New York, NY 10011

MEP/FP Engineer
AKF Group
One Liberty Plaza
165 Broadway, 22 Floor
New York, New York 10006

Geotechnical Engineer
Mueser Rutledge
225 West 34th Street, 10th Floor
New York, NY 10122

Civil Engineer
Stonefield Engineering & Design LLC
75 Orient Way, Suite 303
Rutherford, NJ 07070

Building Envelope Consultant
Vidaris, Inc.
360 Park Avenue South, 15 Floor
New York, NY 10010

Facade Maintenance Consultant
Entek Engineering, LLC
Hackensack, NJ 07601
160 Ames Street

Vertical Transportation Consultant
Joseph Neto & Associates
1430 Broadway, Suite 908
New York, New York 10006

Acoustics Consultant
Longman Lindsey
1410 Broadway, Suite 508
New York, NY 10018

PROJECT NUMBER: MRCE #12509

DATE: 12-08-2016

REVISIONS:

DOB FILING	09-26-16
BD SET	10-10-16
CONSTRUCTION DOCUMENTS	11-01-16
100% CONSTRUCTION DOCUMENTS	12-08-16

SCALE: AS NOTED

DRAWING NAME:

SUPPORT OF
EXCAVATION DETAILS
1 OF 2

DRAWING NUMBER:

SOE-105.00

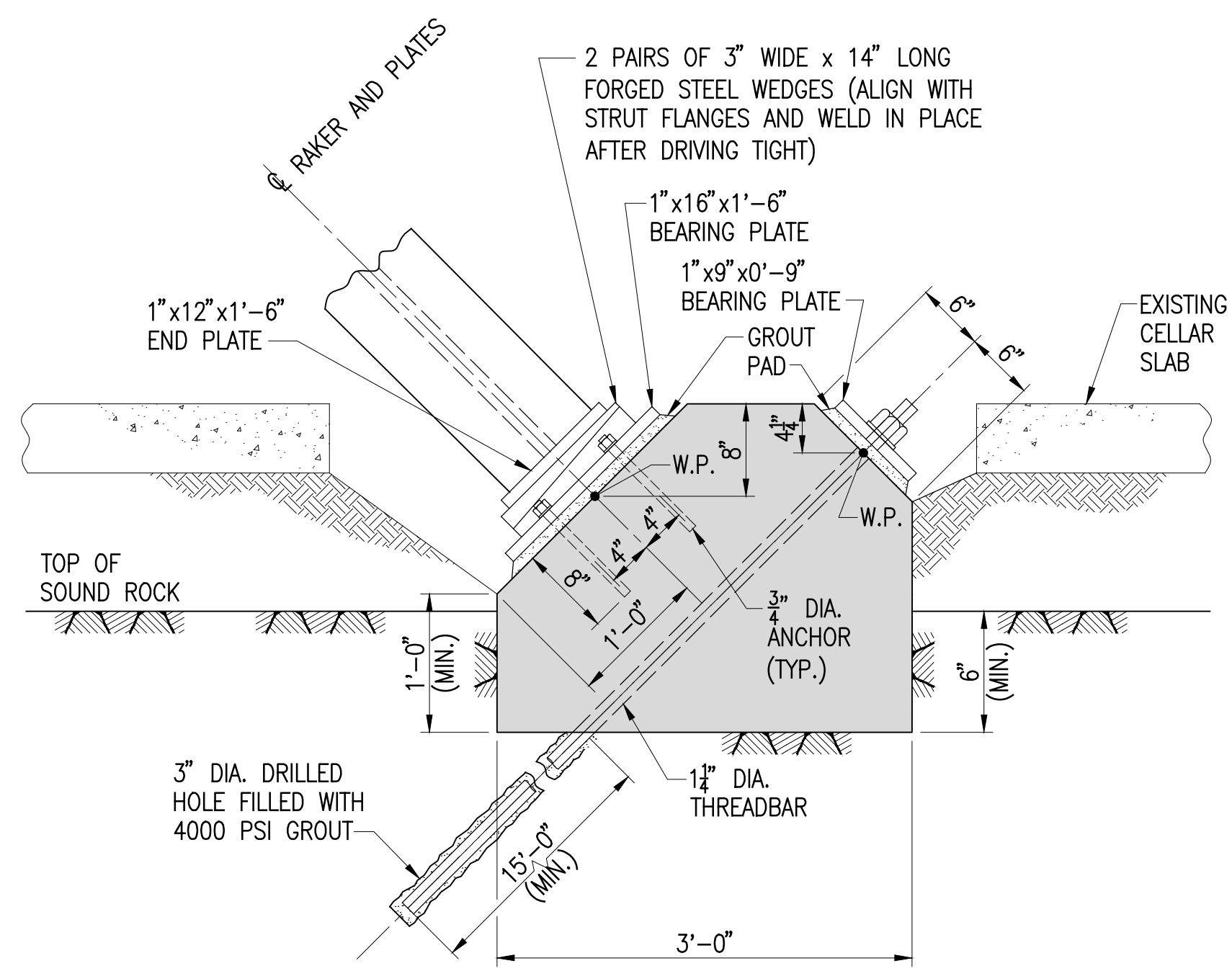

TYPICAL HEEL BLOCK DETAIL
SCALE: 1"=1'-0"

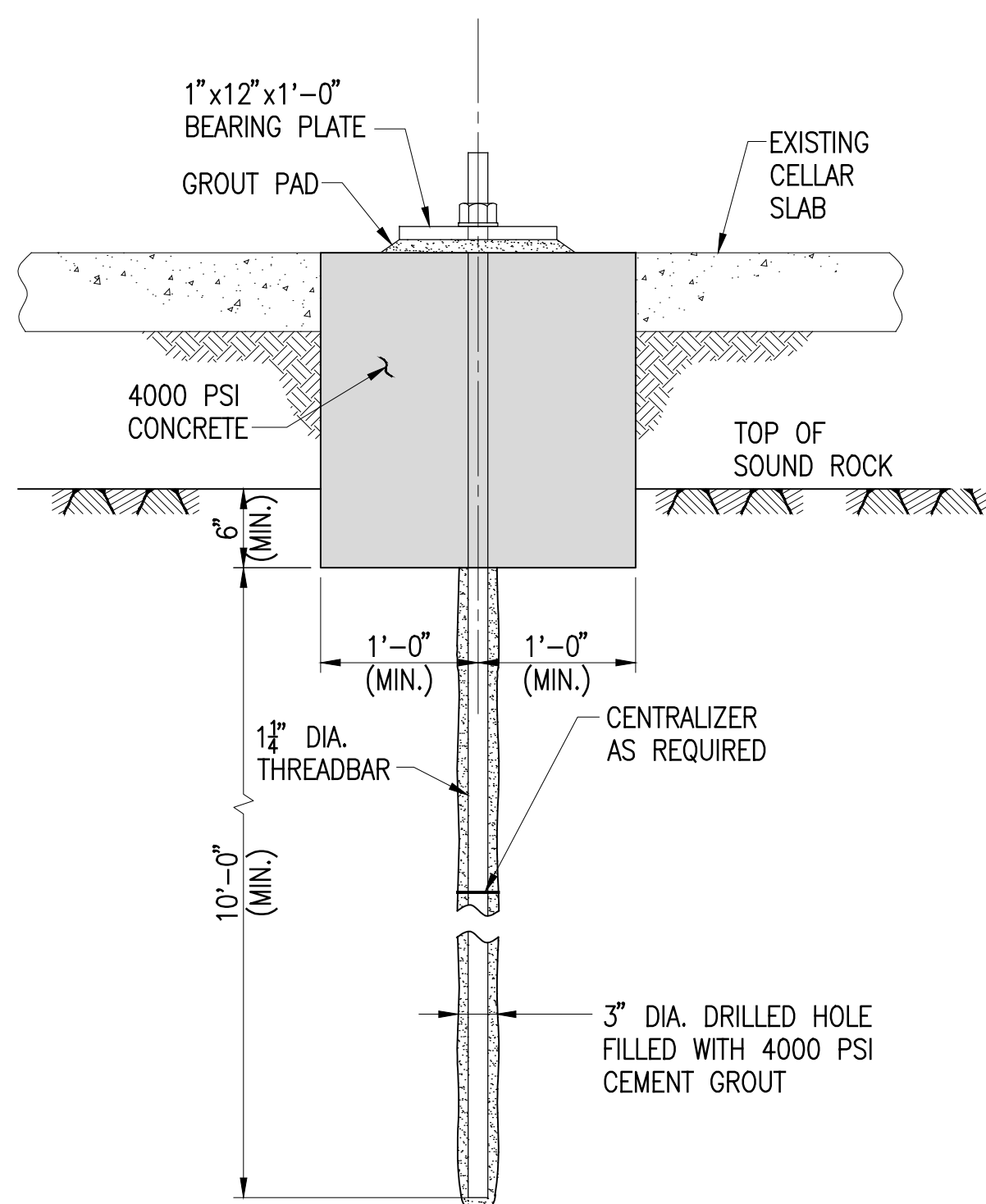

TYPICAL SLAB PIN DETAIL
SCALE: 1"=1'-0"

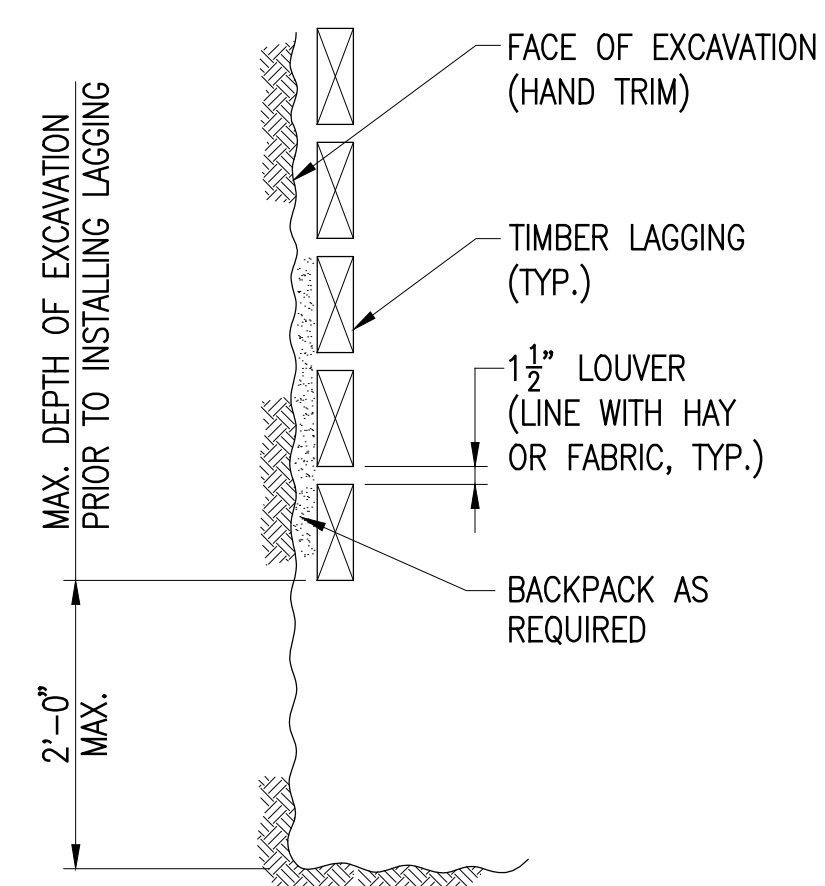

TYPICAL LAGGING INSTALLATION DETAIL
SCALE: 3/4"=1'-0"

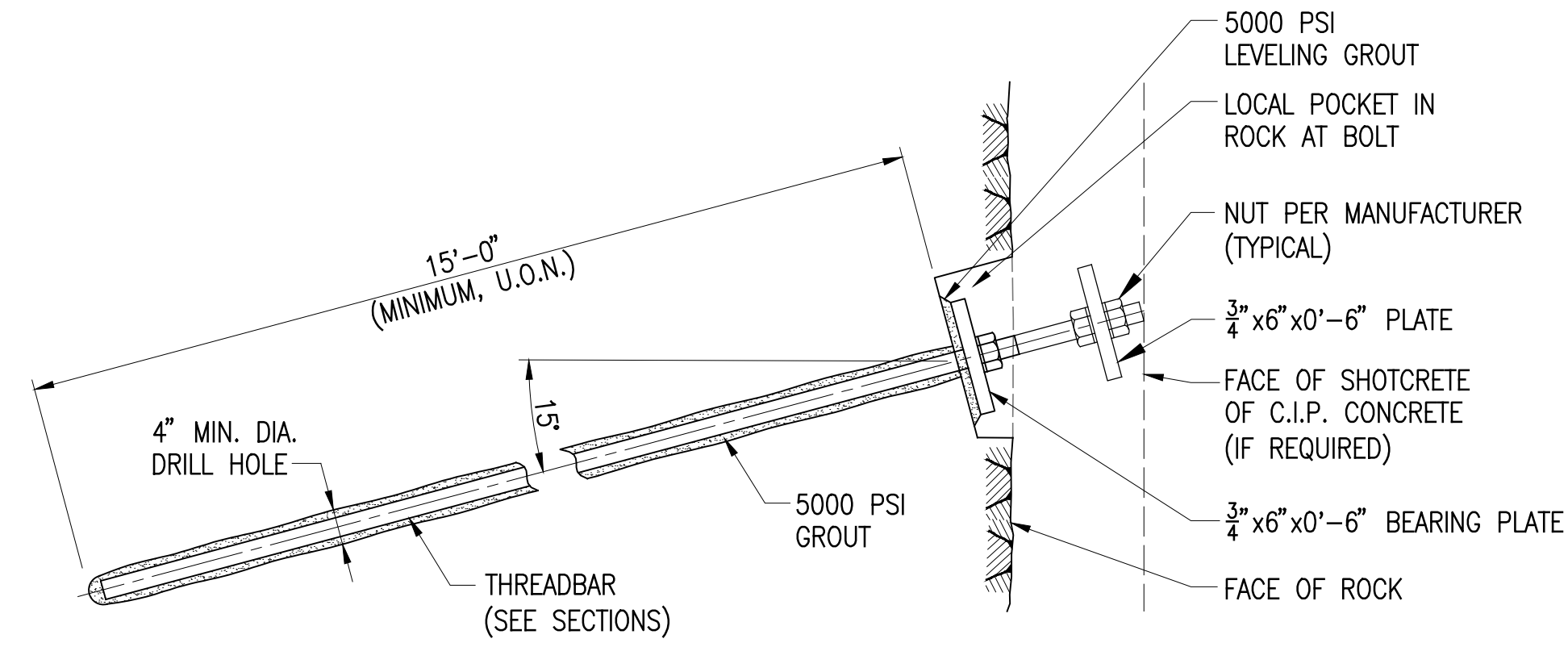

TYPICAL ROCK BOLT DETAIL
SCALE: NO SCALE

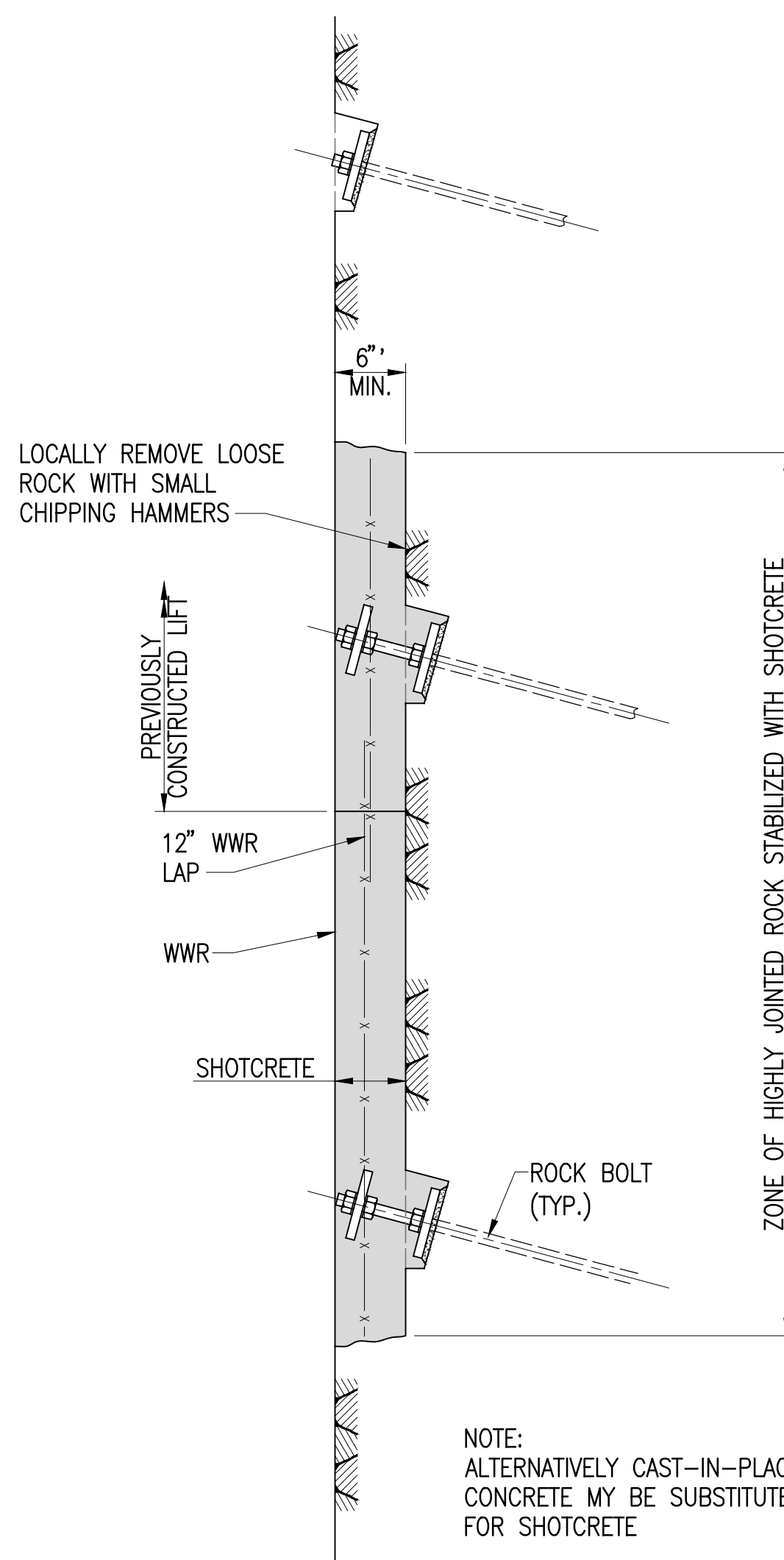

TYPICAL ROCK FACE SHOTCRETE DETAIL
SCALE: 1"=1'-0"

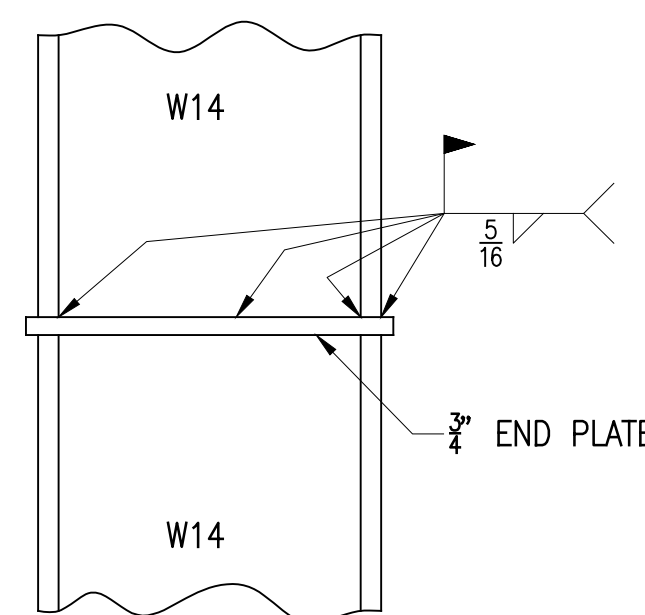

TYPICAL WALE SPLICE DETAIL
SCALE: 1-1/2"=1'-0"

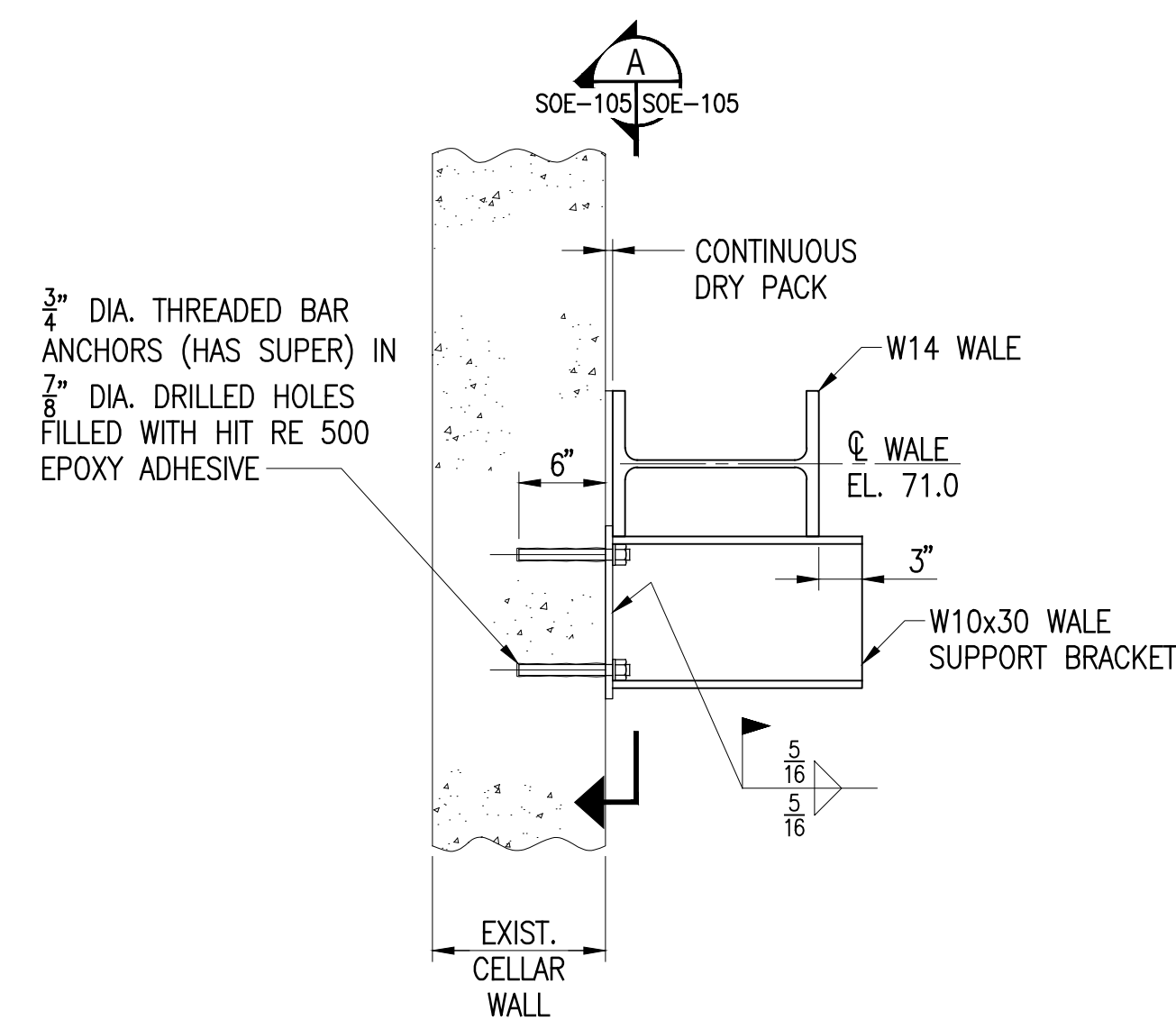

TYPICAL WALE SUPPORT BRACKET DETAIL
SCALE: 1"=1'-0"

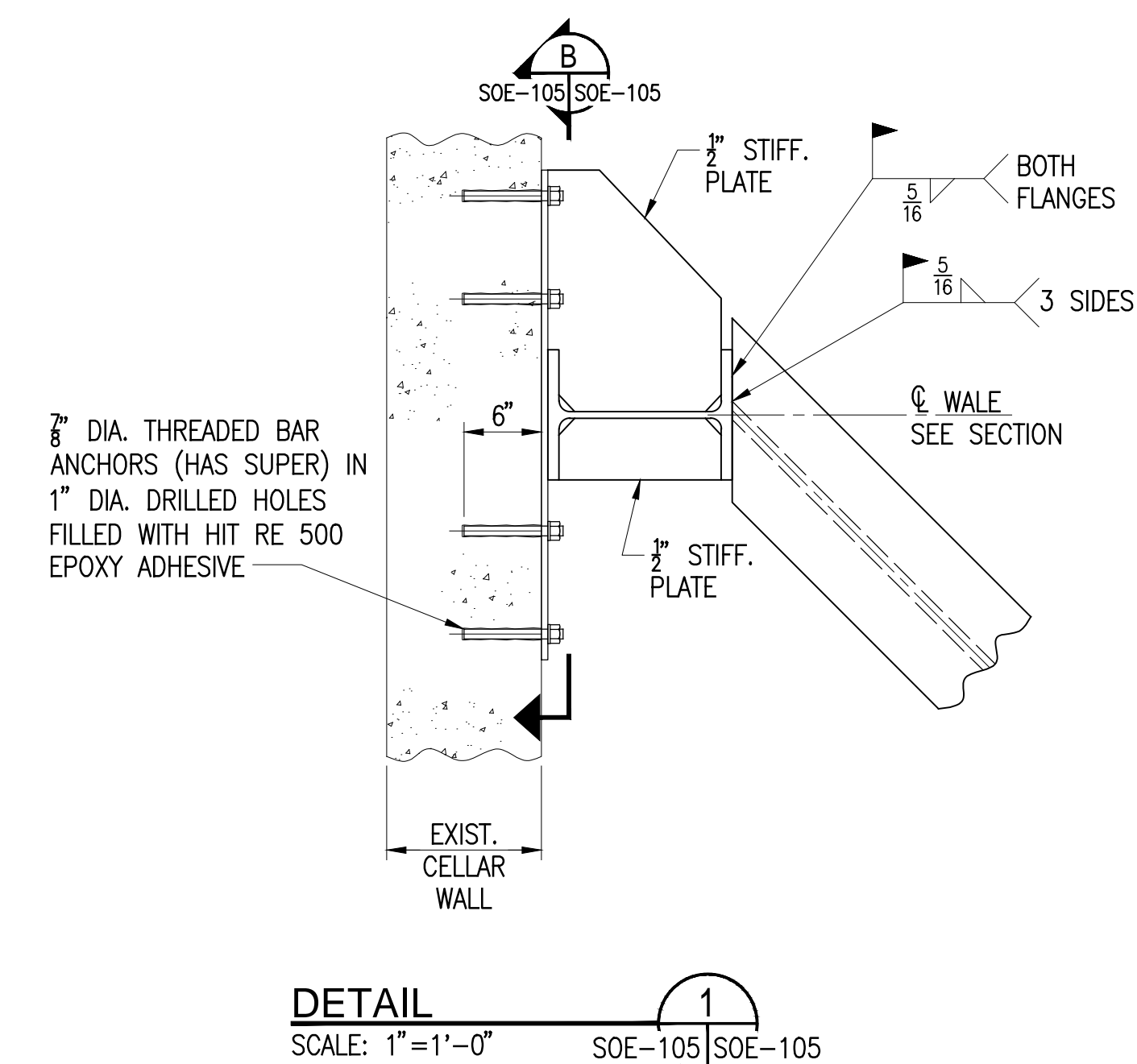

DETAIL 1
SCALE: 1"=1'-0"

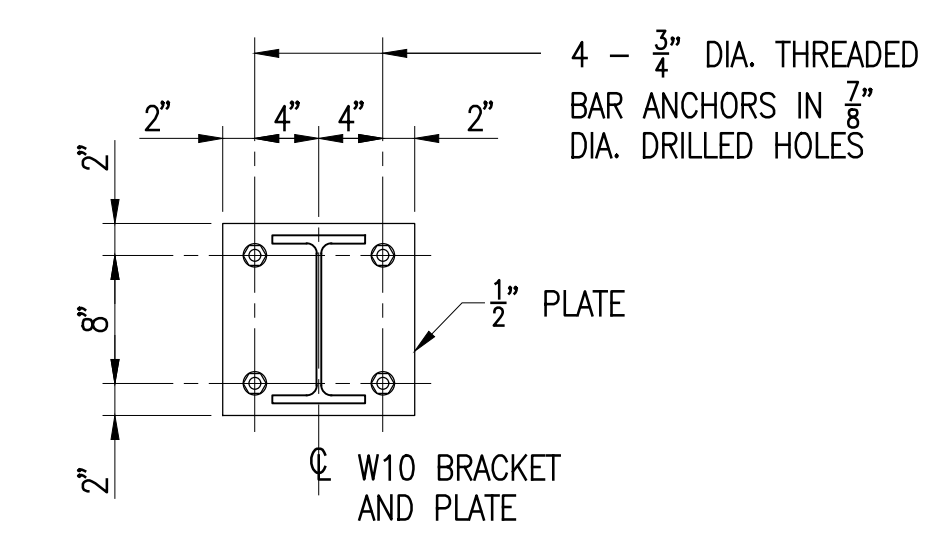

NOTE: WALE NOT SHOWN FOR CLARITY.

SECTION A
SCALE: 1"=1'-0"

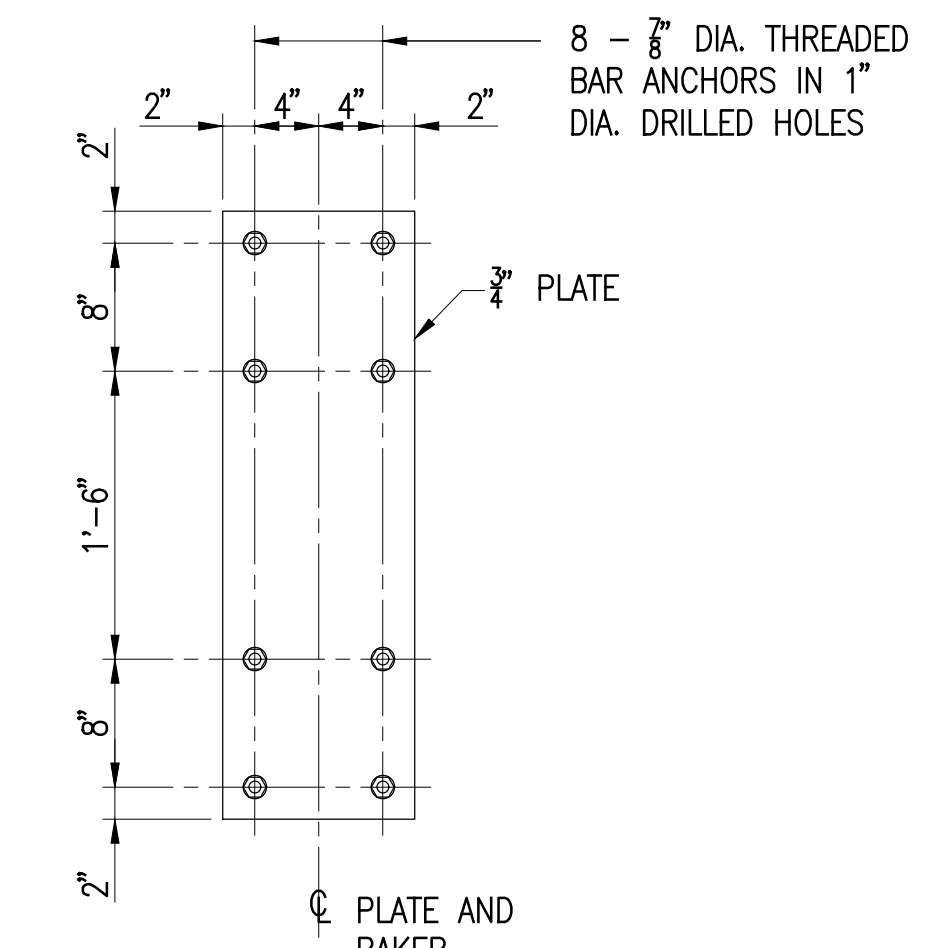

NOTE: WALE NOT SHOWN FOR CLARITY.

SECTION B
SCALE: 1"=1'-0"

